

# PFC

**BRAKES**



## **BRAKE UPGRADES**

Effective March 2018 - Issue 18

## CONTENTS

Caliper & Pad Technology	3	Brake Pad Applications	11
Disc Technology	4	Pad Compounds	16
Z-Rated Brake Kits	5	PFC Pads for Competitors' Kits	18
Z-Rated Brake Kit - Replacement Parts	9	Brake Pad Profiles	19
Direct Drive OE Disc Assemblies	9	Brake Fluid and Accessories	26
Replacement Brake Discs for Competitors' Kits	10		

## COMPANY PROFILE

**Performance Friction®** brake calipers, discs and pads are manufactured in our state of the art production plant located in Clover, South Carolina. With world-class manufacturing processes in place, our 200,000 square foot, 400 plus employee facility supplies major automotive retailers, thousands of workshops and vehicle manufacturers in domestic and international markets. With offices in Europe, Australia, Mexico and Japan, Performance Friction® is able to stay connected to its customers around the world.



**Performance Friction UK** is the sales, distribution and technical support centre for EUROPE, providing assistance to a network of regional distributors throughout the EMEA

(Europe, Middle East and Africa) region, from a 7,000 square foot facility, holding stock of over 2,000 product lines.



**At Performance Friction®, every employee has "passion for the product." And It Shows...**

Performance Friction® continues to be the market leader wherever drivers demand unrivaled performance and quality, No Compromises™.

Our brake calipers, discs and pads outperform the competition in all markets, from professional racing to commercial fleets.

**Street** - It's Quieter, Stops Quicker and Lasts Longer. At Performance Friction® we don't just

copy OE, we make it better. Whether you're driving a sports car, saloon, truck or recreational vehicle, we make application specific Z-Rated® Big Brake Kits, Carbon Metallic® brake pads and OE direct replacement Direct Drive™ discs. Our range of two-piece discs last longer and reduce vibration caused by thermal distortion and warping.

**Fleet and Off-highway** - Lower Cost Per Mile. Many leading operators rely on Performance Friction® discs and Carbon Metallic® brake pads to deliver the lowest cost per mile and highest durability in the industry. In the off-highway market Performance Friction® was the first brake pad supplier to produce an asbestos-free solution to stop a 300-ton truck at 35 mph.

**Z-Rated®** - It's Quicker, It's Cooler, It's Patented. Every year hundreds of major championships around the world are won with Performance Friction® Z-Rated® calipers, Direct Drive™ discs and Carbon Metallic® pads. What's our secret? No single attribute makes us the best. We engineer our calipers, discs and pads to work together as a system to give drivers superior control, the lowest lap times and unrivaled reliability.

## HOW TO FIND US

Our European Headquarters located at Banbury in Oxfordshire is extremely well serviced by road, rail and air transport.

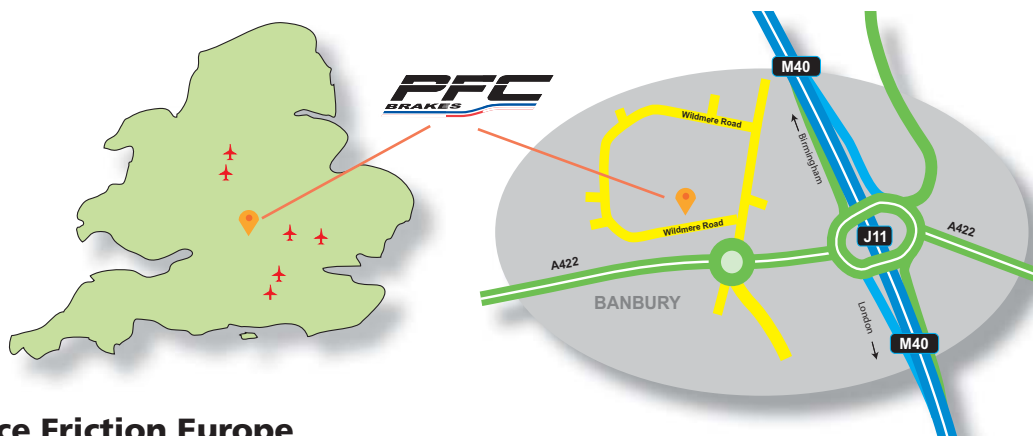

## Performance Friction Europe

Carbon Metallic House, Wildmere Road, Banbury, Oxon OX16 3LU United Kingdom  
uksales@pfcbrakes.com www.pfcbrakes.eu

Tel: +44(0)1295 221020 Fax: +44(0)1295 279711

## Caliper Technology

### The System...

The caliper, disc and pads work as a system: dynamically effecting bite, torque and release.

Performance Friction's improvements in pad and disc technology, combined with improvements in caliper design, result in exceptional performance and reliability.

**Short Aspect Ratio 4-Piston Design** for a stiffer caliper body, which reduces drag and temperature as well as improving release and control over 6-piston designs.

**Integrated Piston dust Boots**

**High Tension Seals** for proper piston rollback, which reduces drag and improves consistency.

**High Temperature Aluminium Alloy** for stiffness and improved pedal feel at the highest temperatures.

**Monobloc Finite Element Analysis Design** reduces caliper deflection for less pedal travel and improved response.

**Abutment Design** for optimized torque takeout, which improves release and control.

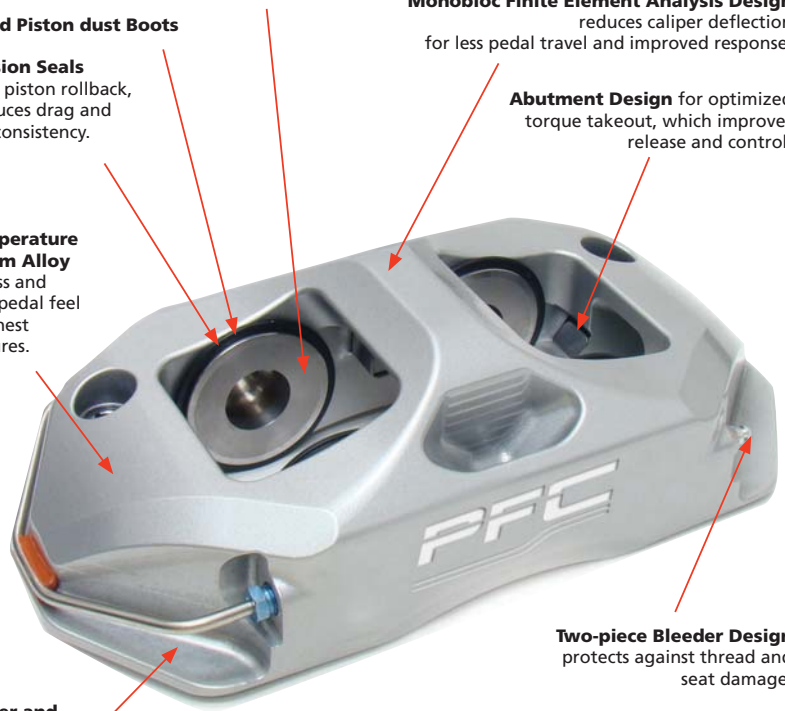

**Integrated Bleeder and Bridge Pipe Guards.**

**Two-piece Bleeder Design** protects against thread and seat damage.

## Brake Pad Technology

The Latest in Brake Pad Technology for specific Severe Duty and High Performance Applications

**Sports and Trackday** – more stopping power and increased fade resistance for the high performance driver that demands better than OE to get the most from their high performance sports car.

- **More stopping power**
- **Fade resistant**
- **Quieter**
- **High pad life**
- **Lower disc wear**
- **Low dusting**

### Multi-Layer Technology™

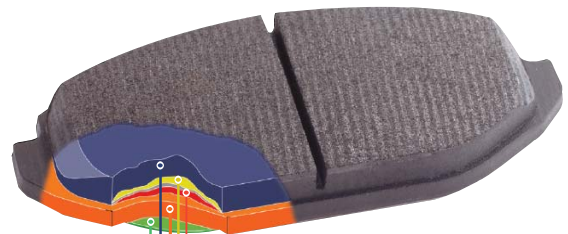

Each layer reduces brake noise by absorbing specific ranges of sound frequencies.

**Layer 1** Vehicle specific formulated friction materials - this means exceptional stopping power over a longer performance life.

**Layer 2** Enhanced material technology - exclusive underlayment - this means it isolates, dampens and reduces noise.

**Layer 3** Exclusive Ionic Fusion™ bonding technology - this means dependable braking under severe conditions and it prevents delaminating.

**Quality Steel** Statistically controlled plates to ensure proper fit.

**Visco-Elastic Shims** Multi-Layer, noise insulating Visco-elastic shims are the final barrier to noise and vibration.

**Patented graphite enhanced powder coating** - prevents steel plate corrosion to improve pad life.

Z-Rated ® Carbon Metallic ® is denoted with a part number ending in .10 or .11  
For example: BMW E46 M3 - 0394.11

## Two-Piece Floating Direct Drive™ Street Upgrade Disc Technology

Ever since the disc brake was invented vibration and pulsation caused by thermal expansion (warped discs) has been a major issue.

### Until Now...

With Performance Friction's two-piece floating Direct Drive and Direct Drive 'V2' disc assemblies, the disc flange floats in the bobbin structure, allowing radial and axial expansion of the disc without being constrained by the hub or hat.

Years of R&D and thousands of race miles have resulted in the development of PFC's Patented Direct Drive™ Systems.

**Direct Drive™** uses a saddle bobbin as part of the mounting system.

**Direct Drive V2™** is an integral drive in hat system and is a second generation disc mounting system designed to enhance the Z-Rated Big Brake kits by reducing the number of components and overall disc assembly weight.

**Direct Drive V3™** is the very latest generation mounting system that uses a spiral locking ring that connects the disc to the hat - allowing much faster fitting without the need for tools or fixings, and producing even less overall weight.

**A true two-piece floating race disc optimized for road and track duty.**



Direct Drive



Direct Drive V2



Direct Drive V3

- Reduced thermal distortion and warping.
- No rattling – 100% silent operation.

- Reduced drag and increased mileage.
- Reusable hat/hub assembly.

## Direct Drive™ Discs



1. High Carbon Alloy with copper and molybdenum for high temperature strength and durability.
2. Vanes turned OD and ID for balance to reduce thermal warping and vibration.
3. Run-out less than .001 inches, reducing pulsation and vibration.
4. Thickness variation less than .0003 inches reduces vibration.
5. 47 or more vanes for superior thermal capacity.
6. Aircraft quality heat-treated for microstructure alignment and durability.
7. Surface finishes less than .7 microns.
8. 100% measured and inspected to meet tolerance specifications.

## The Result...

PFC Brakes outperform the competition by more efficiently distributing heat for lower lap times, longer life and improved driver control.

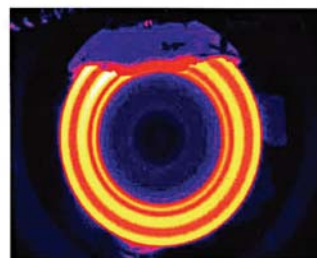

Competitor

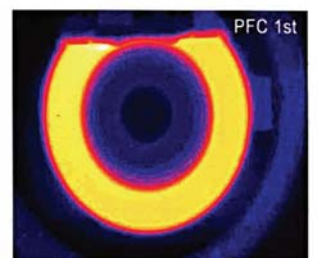

PFC



## HIGH PERFORMANCE BRAKE KITS

- Forged Multipad Monobloc Caliper • Direct Drive V2 / V3 Molybdenum Alloy Discs
- Z-Rated® Carbon Metallic® Pads • Custom Engineered for Street and Track use • Genuine Race Technology
- Custom Colours • Stainless Steel Braided Hoses • Caliper Mounting Brackets and Fittings

APPLICATION	YEAR	KIT	CALIPER	TYPE	PISTONS	DUST BOOTS	DISC SIZE	DISC PATTERN	PAD	PART No.
BMW 135i (E81/E82)	2008 >	Front	ZR31	MONOBLOC	4	YES	355 x 32mm	DIMPLED SLOTTED	7861	1090.0001 1090.0002
		Rear	ZR31	MONOBLOC	4	YES	355 x 30mm	DIMPLED SLOTTED	7863	1091.0001 1091.0002
BMW 1M	2011 >	Front	ZR31	MONOBLOC	4	YES	372 x 32mm	DIMPLED SLOTTED	7861	3100.0008 3100.0028
		Rear	ZR31	MONOBLOC	4	YES	371 x 30mm	DIMPLED SLOTTED	7863	0031.0003 0031.0023
BMW 330i / 335i (E90, E92)	2006 >	Front	ZR31	MONOBLOC	4	YES	355 x 30mm	DIMPLED SLOTTED	7863	3100.0003 3100.0023
		Rear	ZR31	MONOBLOC	4	YES	371 x 30mm	DIMPLED SLOTTED	7863	0031.0002 0031.0022
BMW M3 (E36) 3.2	1995-1999	Front	ZR31	MONOBLOC	4	YES	355 x 32mm	DIMPLED SLOTTED	7863	3100.0006 3100.0026
BMW M3 (E36) 3.2 *race application	1995-1999	Front	ZR45	2-PIECE	4	NO	323 x 32mm	SLOTTED	7852	4500.0001
		Front	ZR45	2-PIECE	4	NO	323 x 29mm	DIMPLED SLOTTED	7852	4500.0012 4500.0002
		Front	ZR39	MONOBLOC	4	NO	323 x 32mm	DIMPLED SLOTTED	7831	3900.0002 3900.0022
BMW M3 (E36)	1995-1999	Rear	ZR29 <sup>o</sup>	2-PIECE	2	YES	321 x 20mm	DIMPLED SLOTTED	7929	0029.0003 0029.0004
BMW M3 (E46) *race application	2001 - 2006	Front	ZR39	MONOBLOC	4	NO	323 x 32mm	DIMPLED SLOTTED	7831	3900.0001 3900.0021
		Front	ZR45	2-PIECE	4	NO	323 x 32mm	DIMPLED SLOTTED	7852	1556.0011 1556.0001
		Front	ZR45	2-PIECE	4	NO	355 x 32mm	SLOTTED DIMPLED	7852	4500.0003 4500.0033
BMW M3 (E46)	2001- 2006	Front	ZR31	MONOBLOC	4	YES	355 x 32mm	DIMPLED SLOTTED	7863	3100.0004 3100.0024
BMW M3 (E46)	2001- 2006	Rear	ZR29 <sup>o</sup>	2-PIECE	2	YES	321 x 20mm	DIMPLED SLOTTED	7929	0029.0002 0029.0022
BMW M3 (E90, E92)	2008 >	Front	ZR31	MONOBLOC	4	YES	372 x 32mm	DIMPLED SLOTTED	7861	3100.0008 3100.0028
		Rear	ZR31	MONOBLOC	4	YES	372 x 30mm	DIMPLED SLOTTED	7863	0031.0003 0031.0023
BMW Z3 M Roadster / M Coupe	1998 - 2002	Front	ZR31	MONOBLOC	4	YES	355 x 32mm	DIMPLED SLOTTED	7863	3100.0006 3100.0026
E85 Z4 M Roadster / M Coupe	2006 - 2008	Front	ZR45	2-PIECE	4	NO	355 x 32mm	DIMPLED SLOTTED	7852	4500.0033 4500.0003
CADILLAC ESCALADE	2007 >	Front	ZR56	MONOBLOC	6	YES	405 x 36mm	DIMPLED SLOTTED	7956	1184.0001 1184.0002
		Rear	ZR31	MONOBLOC	4	YES	371 x 30mm	DIMPLED SLOTTED	7931	1185.0001 1185.0002
CHEVROLET 1500 Avalanche (1/2 Ton)	2007 >	Front	ZR56	MONOBLOC	6	YES	405 x 36mm	DIMPLED SLOTTED	7956	1184.0001 1184.0002
		Rear	ZR31	MONOBLOC	4	YES	371 x 30mm	DIMPLED SLOTTED	7931	1185.0001 1185.0002
CHEVROLET 2500 Avalanche ARMORED (17inch wheel) (3/4 Ton)	2007 >	Front	ZR62	MONOBLOC	6	YES	362 x 35mm	DIMPLED SLOTTED	7962	1040.0001 1040.0002
		Rear	ZR31	MONOBLOC	4	YES	373 x 32 mm	DIMPLED SLOTTED	7861	1041.0001 1041.0002

<sup>o</sup> When using PFC RACE pads, brake kits with ZR29 calipers will require piston cap kits and insulators. Please check with the PFC Europe Sales Department for details.

APPLICATION	YEAR	KIT	CALIPER	TYPE	PISTONS	DUST BOOTS	DISC SIZE	DISC PATTERN	PAD	KIT PART
<b>CHEVROLET CAMARO RS / LS</b>	2010 >	Front	ZR31	MONOBLOC	4	YES	373 x 32mm	DIMPLED SLOTTED	7861	1164.0001 1164.0002
		Rear	ZR31	MONOBLOC	4	YES	373 x 32mm	DIMPLED SLOTTED	7861	1165.0001 1165.0002
<b>CHEVROLET CAMARO SS</b>	2010 >	Front	ZR31	MONOBLOC	4	YES	373 x 32mm	DIMPLED SLOTTED	7861	1166.0001 1166.0002
		Rear	ZR31	MONOBLOC	4	YES	373 x 32mm	DIMPLED SLOTTED	7861	1167.0001 1167.0002
<b>CHEVROLET CORVETTE C5 / C6 Z06</b>	1997- 2006	Front	ZR31	MONOBLOC	4	YES	362 x 32 mm	DIMPLED SLOTTED	7861	3100.0005 3100.0025
		Rear	ZR31	MONOBLOC	4	YES	371 x 30mm	DIMPLED SLOTTED	7863	0031.0001 0031.0021
<b>CHEVROLET 1500 Silverado (1/2 Ton)</b>	2007 >	Front	ZR56	MONOBLOC	6	YES	405 x 36mm	DIMPLED SLOTTED	7956	1184.0001 1184.0002
		Rear	ZR31	MONOBLOC	4	YES	371 x 30mm	DIMPLED SLOTTED	7931	1185.0001 1185.0002
<b>CHEVROLET 2500 Silverado (3/4 Ton) ARMORED (17inch wheel)</b>	2007 >	Front	ZR62	MONOBLOC	6	YES	362 x 35mm	DIMPLED SLOTTED	7962	1040.0001 1040.0002
		Rear	ZR31	MONOBLOC	4	YES	373 x 32mm	DIMPLED SLOTTED	7861	1041.0001 1041.0002
<b>CHEVROLET 500 Suburban (1/2 Ton)</b>	2007 >	Front	ZR56	MONOBLOC	6	YES	405 x 36mm	DIMPLED SLOTTED	7956	1184.0001 1184.0002
		Rear	ZR31	MONOBLOC	4	YES	371 x 30mm	DIMPLED SLOTTED	7931	1185.0001 1185.0002
<b>CHEVROLET 1500 Suburban (1/2 Ton) ARMORED (Small piston rear)</b>	2007 >	Front	ZR56	MONOBLOC	6	YES	405 x 36mm	DIMPLED	7956	5631.0001
		Rear	ZR31	MONOBLOC	4	YES	371 x 30mm	DIMPLED	7931	
<b>CHEVROLET 1500 Suburban (1/2 Ton) ARMORED (Big piston rear)</b>	2007 >	Front	ZR56	MONOBLOC	6	YES	405 x 36mm	DIMPLED	7956	5631.0002
		Rear	ZR31	MONOBLOC	4	YES	371 x 30mm	DIMPLED	7931	
<b>CHEVROLET 2500 Suburban (3/4 Ton) ARMORED (17inch wheel)</b>	2007 >	Front	ZR62	MONOBLOC	6	YES	362 x 35mm	DIMPLED SLOTTED	7962	1040.0001 1040.0002
		Rear	ZR31	MONOBLOC	4	YES	373 x 32mm	DIMPLED SLOTTED	7861	1041.0001 1041.0002
<b>CHEVROLET 1500 TAHOE (1/2 Ton)</b>	2007 >	Front	ZR56	MONOBLOC	6	YES	405 x 36mm	DIMPLED SLOTTED	-	1184.0001 1184.0002
		Rear	ZR31	MONOBLOC	4	YES	371 x 30mm	DIMPLED SLOTTED	7931	1185.0001 1185.0002
<b>FORD F150</b>	2010-2011	Front	ZR56	MONOBLOC	6	YES	405 x 36mm	DIMPLED SLOTTED	7956	1069.0001 1069.0002
<b>FORD F450</b>	2007-	Front	ZR67	MONOBLOC	6	-	-	SMOOTH	-	1509.0001
		Rear	ZR67	MONOBLOC	6	-	-	SMOOTH	-	1114.0001
<b>FORD 450 (Armored)</b>	2007-	Front	ZR67	MONOBLOC	6	-	405 x 36mm	SMOOTH	7967	1509.0002
		Rear	ZR67	MONOBLOC	6	-	405 x 36mm	SMOOTH	7967	1114.0002
<b>FORD F550</b>	2007- 2009	Front	ZR67	MONOBLOC	6	-	-	SMOOTH	-	1509.0001
		Rear	ZR67	MONOBLOC	6	-	-	SMOOTH	-	1114.0001
<b>FORD F550 (Armored)</b>	2007- 2009	Front	ZR67	MONOBLOC	6	-	405 x 36mm	SMOOTH	7967	1509.0002
		Rear	ZR67	MONOBLOC	6	-	405 x 36mm	SMOOTH	7967	1114.0002
<b>FORD MUSTANG GT / V8</b>	2005- 2010	Front	ZR31	MONOBLOC	4	YES	355 x 32mm 355 x 32mm	DIMPLED SLOTTED	7861 7861	3100.0002 3100.0011
<b>SHELBY GT500 MUSTANG</b>	2005-2010	Front	ZR31	MONOBLOC	4	YES	362 x 32mm	DIMPLED	7861	1248.0001
		Rear	OE	MONOBLOC	-	-	328 x 19mm	DIMPLED	1082	0001.0001
<b>FORD MUSTANG (OE Caliper upgrade kit)</b>	2005 >	Rear	OE	-	-	-	328 x19mm	SLOTTED	1082	0001.0002
<b>GMC 1500 SIERRA (1/2 Ton)</b>	2007 >	Front	ZR56	MONOBLOC	6	YES	405 x 36mm	DIMPLED SLOTTED	7956	1184.0001 1184.0002
		Rear	ZR31	MONOBLOC	4	YES	371 x 30mm	DIMPLED SLOTTED	7931	1185.0001 1185.0002
<b>GMC 1500 Yukon / Yukon XL (1/2 Ton)</b>	2007 >	Front	ZR56	MONOBLOC	6	YES	405 x 36mm	DIMPLED SLOTTED	-	1184.0001 1184.0002
		Rear	ZR31	MONOBLOC	4	YES	371 x 30mm	DIMPLED SLOTTED	-	1185.0001 1185.0002

APPLICATION	YEAR	KIT	CALIPER	TYPE	PISTONS	DUST BOOTS	DISC SIZE	DISC PATTERN	PAD	KIT PART
<b>GMC 2500 Yukon XL (3/4 Ton)</b>	2007 >	Front	ZR62	MONOBLOC	6	YES	362 x 35mm	DIMPLED	7962	1040.0001
	Rear	ZR31	MONOBLOC	4	YES	373 x 32mm	DIMPLED SLOTTED		1041.0001 1041.0002	
<b>GMC DENALI / DENALI XL (1/2 Ton)</b>	2007 >	Front	ZR56	MONOBLOC	6	YES	405 x 36mm	DIMPLED SLOTTED	-	1184.0001 1184.0002
	Rear	ZR31	MONOBLOC	4	YES	371 x 30mm	DIMPLED SLOTTED	-	1185.0001 1185.0002	
<b>GMC 2500 DENALI XL (3/4 Ton) (17inch wheel) ARMORED</b>	2007 >	Front	ZR62	MONOBLOC	6	YES	362 x 35mm	DIMPLED SLOTTED	7962	1040.0001 1040.0002
	Rear	ZR31	MONOBLOC	4	YES	373 x 32mm	DIMPLED SLOTTED	7861	1041.0001 1041.0002	
<b>HONDA NSX</b>	1991- 2005	Front	ZR31	MONOBLOC	4	YES	355 x 30mm	DIMPLED SLOTTED	7863	3100.0012 3100.0212
	Rear	ZR31	MONOBLOC	4	YES	355 x 30mm	DIMPLED SLOTTED	7863	0031.0005 0031.0025	
<b>INFINITY G35</b>	2003- 2008	Front	ZR31	MONOBLOC	4	YES	355 x 32mm	DIMPLED SLOTTED	7863	3100.0010 3100.0210
	2003- 2008	Rear	ZR29 °	2-PIECE	2	YES	321 x 20mm	DIMPLED SLOTTED	7929	0029.0005 0029.0025
<b>LEXUS ISF</b>	2008>	Front	ZR31	MONOBLOC	4	YES	372 x 32mm	DIMPLED SLOTTED	7861	3100.0009 3100.0029
	2008>	Rear	ZR31	MONOBLOC	4	YES	355 x 30mm	DIMPLED SLOTTED	7863	0031.0004 0031.0024
<b>LOTUSElise/Exige (Parking brake removal required)</b>	2004- 2010	Front	ZR34	MONOBLOC	4	NO	323 x 32 mm	DIMPLED SLOTTED		1320.0001 1320.0002
	2004- 2010	Rear	ZR29 °	2-PIECE	2	YES	298 x 20mm	DIMPLED SLOTTED	7929	1321.0001 1321.0002
<b>MINI - BMW Mini Cooper (Requires 20mm wheel spacer)</b>	2007 >	Front	ZR34	MONOBLOC	4	NO	299 x 32mm	DIMPLED SLOTTED	7934	1345.0001 1345.0002
	Rear	ZR29 °	2-PIECE	2	YES	321 x 20mm	DIMPLED SLOTTED	7929	1346.0001 1346.0002	
<b>MITSUBISHI Lancer EVO 7, 8, 9"</b>	2003- 2006	Front	ZR31	MONOBLOC	4	YES	362 x 32mm	DIMPLED SLOTTED	7863	3100.0007 3100.0027
	Rear	ZR29	2-PIECE	2	YES	330 x 22mm	DIMPLED SLOTTED	7929	1363.0001 1363.0002	
<b>MITSUBISHI Lancer EVO 10</b>	2007 >	Front	ZR31	MONOBLOC	4	YES	362 x 32mm	DIMPLED SLOTTED	7863	3100.0001 3100.0021
	Rear	ZR29 °	2-PIECE	2	YES	330 x 22mm	DIMPLED SLOTTED	7929	0029.0001 0029.0021	
<b>NISSAN 350 Z</b>	2003- 2008	Front	ZR31	MONOBLOC	4	YES	355 x 32mm	DIMPLED SLOTTED	7863	3100.0010 3100.0210
	Rear	ZR29 °	2-PIECE	2	YES	321 x 20mm	DIMPLED SLOTTED	7929	0029.0005 0029.0025	
<b>TOYOTA - SCION XD (Rally Kit)</b>	2004 >	Front	ZR34	MONOBLOC	4	NO	295 x 28mm	DIMPLED SLOTTED	7934	3400.0001 3400.0002
<b>SUBARU LEGACY</b>	2010 >	Front	ZR31	MONOBLOC	4	YES	355 x 32mm	DIMPLED SLOTTED	7861	1444.0001 1444.0002
	Rear	ZR29 °	2-PIECE	2	YES	330 x 22mm	DIMPLED SLOTTED	7929	1445.0001 1445.0002	
<b>SUBARU WRX / STi</b>	2004 >	Front	ZR31	MONOBLOC	4	YES	355 x 32mm	DIMPLED SLOTTED	7861	1444.0001 1444.0002
	Rear	ZR29 °	2-PIECE	2	YES	330 x 22mm	DIMPLED SLOTTED	7929	1445.0001 1445.0002	

\* - Z Rated brake kits have been designed to fit most 18" wheels and some smaller sizes. Confirmation of fitment with the use of a template gauge (available from PFC) is required before placement of order as various makes and styles of wheels, OE and aftermarket, can be fitted to the same vehicle model.

° When using PFC **RACE** pads, brake kits with ZR29 calipers will require piston cap kits and insulators. Please check with the PFC Europe Sales Department for details.

## Two-Piece Floating Direct Drive™ Disc Upgrade Application List

Application	Mounting	Part Number	Front Pad	Rear Pad
<b>ASTON MARTIN</b>				
<b>DB9, Vantage V8 – 2003 &gt;</b> Hat and floating disc assembly (Slotted) Replacement disc and fitting kit for above assembly	Front	TBA 355.32.0060.07/08	1001 / 7781	1053 / 0592
<b>DB9, Vantage V8 - 2003 &gt;</b> Hat and floating disc assembly (Slotted V2) Replacement disc for above assembly	Rear	TBA 328.28.0050.45/46	1001 / 7781	1053 / 0592
<b>BMW</b>				
<b>E36 M3 / Z3, 1995 &gt; 00,</b> Hat and floating disc assembly (Slotted V3) Replacement disc for 311.053.63/64	Front	311.053.63/64 311.28.0054.451/461	0394	0396
<b>E46 M3 CSL 2000 &gt; 06,</b> Hat and floating disc assembly (Slotted V3) Replacement disc for above assembly 341.053.63/64	Front	341.053.63/64 341.29.0053.451/461	0394	0548
<b>E46 M3, 2001 &gt; 06,</b> Hat and floating disc assembly (Slotted V3) Replacement disc for above assembly 322.053.63/64	Front	322.053.63/64 322.28.0054.451/461	0394	0548
<b>E46 M3, 2003 &gt;</b> Hat and floating disc assembly (Dimpled) Replacement disc for 328.061.87/88	Rear	328.061.87/88 328.20.0050.87/88	0394	7855
<b>E82 1 M Coupe, 2010 &gt;</b> Hat and floating disc assembly (Slotted V3) Replacement disc for 357.062.63/64	Front	357.062.63/64 357.30.0064.451/461	0918	0919
<b>E85/86 Z4 M 2004 &gt; 2008</b> Hat and floating disc assembly (Slotted V3) Replacement disc for 341.053.63/64	Front	341.053.63/64 341.29.0053.451/461	0394	0548
<b>E90 / 92 / 93 M3, 2006 &gt;</b> Hat and floating disc assembly (Slotted V3) Replacement disc for 357.062.63/64	Front	357.062.63/64 357.30.0064.451/461	0918	0919
<b>E90 / E91 330i, 2004 &gt;</b> Hat and floating disc assembly (Slotted V3)	Front	328.073.63/64	1061	1171
<b>CHEVROLET CORVETTE</b>				
<b>C5 / C6, (STD model) 1997 &gt; 06,</b> Hat and floating disc assembly (Slotted V3) Replacement disc for above assembly 323.045.63/64	Front	323.045.63/64 323.32.0051.451/461	0731	0732
<b>FERRARI</b>				
<b>360 Modena / F430,</b> Hat and floating disc assembly (Slotted V3) Replacement disc for above assembly 330.041.63/64	Front / Rear	330.041.63/64 330.28.0051.451/461	1053	1053
<b>FORD</b>				
<b>Mustang Cobra, 1995 &gt; 04 -</b> Hat and floating disc assembly (Slotted V3)	Front	330.043.63/64	0412	0627
<b>HONDA</b>				
<b>S2000, 1999 &gt;</b> Hat and floating disc assembly (Slotted V3) Replacement disc for 300.040.63/64	Front	300.040.63/64 300.25.0048.451/461	0829	0537
<b>LOTUS</b>				
<b>EXIGE / 211,</b> Hat and floating disc assembly (Slotted V3) Replacement disc for 308.048.63/64	Front	308.048.63/64 308.26.0044.451/461	7834 / 0109	7824 / 0491
<b>MITSUBISHI</b>				
<b>Evo, V to IX, 1997 &gt; 08,</b> Hat and floating disc assembly (Slotted V3) Replacement disc for 319.044.63/64	Front	319.044.63/64 319.32.0060.451/461	1001 / 7781	0109
<b>Evo V to IX, 1997 &gt; 08,</b> Hat and floating disc assembly (Slotted V3) Replacement disc for 300.058.63/64	Rear	300.058.63/64 300.22.0046.451/461	1001 / 7781	0109
<b>Evo, X, 2008 &gt;</b> Hat and floating disc assembly (Slotted V3) Replacement disc for 348.044.63/64	Front	348.044.63/64 348.32.0060.451/461	1001 / 7781	1368
<b>NISSAN</b>				
<b>350Z, 2003 &gt;</b> (Brembo) Hat and floating disc assembly (Slotted V3) Replacement disc for 324.049.63/64	Front	324.049.63/64 324.30.0053.451/461	0960	0109
<b>R32, 33, 34 GTR, 93 &gt;</b> (Brembo) Hat and floating disc assembly (Slotted V3) Replacement disc for 324.054.63/64	Front	324.054.63/64 324.30.0053.451/461	0960	0109
<b>GT-R35, 08 &gt; 11</b> Hat and floating disc assembly (Slotted V3) Replacement disc for 376.049.63/64	Front	376.049.63/64 376.34.0064.451/461	4362	7780
<b>GT-R35, 2011 &gt;</b> (Upgrade) Hat and floating disc assembly (Slotted V3) Replacement disc for 405.049.63/64	Front	405.049.63/64 405.34.0065.451/461	4362	7780
<b>GT-R35, 08 &gt;</b> Hat and floating disc assembly (Slotted V3) Replacement disc for 381.062.63/64	Rear	381.062.63/64 381.30.0053.451/461	4362	7780



Application	Mounting	Part Number	Front Pad	Rear Pad
<b>PORSCHE</b>				
<b>986, Boxster S, 96 &gt; 05</b> , Hat and floating disc assembly (Slotted V3) Replacement disc for 318.067.63/64	Front	318.067.63/64 318.28.0061.451/461	0776	0738
<b>987, Boxster 3.2 / 3.4 Models, 05 &gt;</b> Hat and floating disc assembly (Slotted V3) Replacement disc for 318.067.63/64	Front	318.067.63/64 318.28.0061.451/461	0776	0738
<b>996, C2 / C4, 97 &gt; 05</b> , Hat and floating disc assembly (Slotted V3) Replacement disc for 318.067.63/64	Front	318.067.63/64 318.28.0061.451/461	0776	0738
<b>996, GT3 / 2 / RS, 98 &gt; 04</b> , Hat and floating disc assembly (Slotted V3) Replacement disc for 350.068.63/64	Front	350.068.63/64 350.34.0060.451/461	7819* / 0991	0776
<b>997, C2 / C4, 04 &gt; 11</b> , Hat and floating disc assembly (Slotted V3) Replacement disc for 318.067.63/64	Front	318.067.63/64 318.28.0061.451/461	0776	0738
<b>997, GT3 / 2 / RS, 04 &gt; 08</b> , Hat and floating disc assembly (Slotted V3) Replacement disc for 350.068.63/64	Front	350.068.63/64 350.34.0060.451/461	7819* / 0991	0776 / 1299
<b>997, GT3 / RS / Turbo, 05 &gt; 11</b> , Hat and floating disc assembly (Dimpled V2) Replacement disc for 348.076.85/86	Rear	348.076.85/86 348.29.0060.43/44	7819	1299
<b>997, GT3, 2011 &gt;</b> PCCB & Iron, Hat and floating disc assembly (Slotted V3) (Standard & centre lock wheels) Replacement disc for 379.067.63/64	Front	379.067.63/64 379.34.0066.451/461	0991	1299
<b>997, Turbo, C4, 2011 &gt;</b> PCCB & Iron, Hat and floating disc assembly (Slotted V3) (Inc road centre lock wheels) Replacement disc for 379.069.63/64	Front	379.069.63/64 379.34.0066.451/461	0991	1299
<b>997, All Gen II cars, 2011 &gt;</b> PCCB & Iron, Hat and floating disc assembly (Dimpled V2) Replacement disc for 348.076.85/86	Rear	348.076.85/86 348.29.0060.43/44	0991	1299
<b>RENAULT</b>				
<b>Megane II RS / Clio RS</b> , (Upgrade) Hat and floating disc assembly (Slotted V3) Replacement disc for 330.063.63/64	Front	330.063.63/64 330.28.0051.451/461	7871	0340
<b>Megane III 250 RS</b> (Upgrade) Hat and floating disc assembly (Slotted V3) Replacement disc for 348.064.63/64	Front	348.064.63/64 348.29.0060.451/461	1001 / 7781	0340
<b>SUBARU</b>				
<b>Impreza WRX, 99 &gt; 01</b> , Hat and floating disc assembly (Slotted V3) Replacement disc for 293.057.63/64	Front	293.057.63/64 293.25.0047.451/461	0460	0461
<b>Impreza WRX STi</b> , Brembo Caliper - 2001- hat and floating disc assembly (Slotted V3) Replacement disc for above assembly 326.053.63/64	Front	326.053.63/64 326.30.0061.451/461	1001 / 7781	0109

\* 7819 use on 350mm PFC discs





## Replacement Brake Discs for Competitors Kits

Performance Friction is pleased to offer a range of discs to replace and upgrade your AP Racing / Brembo discs. Available as a direct replacement, our discs offer an option for the discerning performance road car user who is looking for a performance upgrade, without having to discard their AP Racing calipers and disc bells. To make the most of upgrading to our replacement discs, we strongly advise the use of Performance Friction pads to complement the set-up for ultimate performance. One of the key criteria to an effective brake system is to make sure the contact surfaces between the pad and the disc are flat. Discs are prone to major thermal variances and inconsistent load cycles, and these effects can cause the disc to distort and therefore decrease the performance of the braking system.

### Performance Friction disc enhancements include:

- Reduced Brake Pulsation.
- Reduced Thermal Fatigue.
- Reduced Brake Judder.
- Reduced Noise, Vibration and Harshness.
- Reduced Brake Drag.

OE Part Number	PFC Number	Popular Applications	Dia (mm)	Thickness (mm)	Pad swept area (mm)	Disc mtg PCD (mm)	Disc mtg hole (mm)	No. bolt mtg holes (mm)
CP5000-510/511	295.25.0044.03/04	Lotus Elise / Exige	295	25.4	45	177.8	6.4	12
CP3580-102/103	295.28.0051.03/04	Honda, Peugeot, BMW, Vauxhall, VW	295	28	51	177.8	6.4	12
CP3580 - 2572/2573	304.28.0049.01/02	AP Rally Applications	304	28	51	177.8	6.4	12
CP3581-1131/1130	328.32.0049.03/04*	V8 Star rear	328	32	50	202	11.6 x 9.3	12
CP3580-2899/2898	330.28.0049.03/04	Audi, BMW, Ford, Honda, Mazda, Mitsubishi, Saab, Seat, Subaru, Vauxhall, VW	330	28	51	203	6.4	12
Brembo various	332.32.0052.03/04	Lamborghini Gallardo GT3 rear	332	32	52	210	9.5 x 8.1	10
CP3581-767/766	332.32.0056.03/04	Mitsubishi Evo	332	32	57	203	6.4	12
CP3581-543/542	343.32.0054.03/04	BMW, Saab	343	32	55	216	6.4	12
Brembo various	355.32.0048.03/04	Porsche / Viper, rear	355	32	50	233	11.4 x 8.1	10
Brembo various	355.32.0051.03/04	Porsche GT3, rear	355	32	53	233	11.4 x 8.1	10
CP3581-1081/1080	355.32.0051.05/06*	TVR GT rear	355	32	53	228	11.4 x 8.1	12
CP3581-537/536	356.32.0054.03/04	BMW, Saab	356	32	56	228	6.4	12
CP3718-1069/1068	362.32.0055.03/04	Mitsubishi Evo	362	32	56	228	6.4	12
CP3718 - 1030/1031	378.32.0053.03/04*	V8 Star front	378	32	54	239	11.6 x 9.3	12
Brembo various	378.32.0051.03/04	Aston Martin DBRS9 GT3	378	32	53	256.8	9.7 x 8.1	10
CP3718-1031/1030	378.32.0053.03/04*	Various	378	32	55	239	11.6 x 9.3	12
Brembo various	378.32.0060.03/04	Porsche 997 GT3 Cup, front	378	32	62	235.6	8.4	10
Brembo various	378.35.0051.03/04	Dodge Viper front	378	35	53	256.8	9.7 x 8.1	10

\* Use bobbin 900.700.113.04



## Brake Pad Applications

Make/Year	Model	Application	Front	Rear
<b>ALFA ROMEO</b>				
03-	156 3.2 GTA	Brembo Caliper	1001 / 7781	-
98-	166 2.0 V6	Brembo Caliper	1001 / 7781	-
03-	166 2.4 JTD	Brembo Caliper	1001 / 7781	-
98-00	166 2.5 24v	Brembo Caliper	1001 / 7781	-
98-00	166 3.0 24v	Brembo Caliper	1001 / 7781	-
03-	166 3.2 24v	Brembo Caliper	1001 / 7781	-
05-	Brera	Brembo Caliper	1001 / 7781	-
<b>ASTON MARTIN</b>				
96-97	DB7	Coupe and Convertible	0412	-
99-04	DB7	Brembo Caliper	7780	-
04-	DB9	Brembo caliper	1001 / 7781	0592 / 1053
01-	Vanquish 5.9, 6.0 V12	Brembo Caliper	7780	0592 / 1053
93-96	Vantage	AP Caliper	7767	-
04-	Vantage	Brembo caliper	1001 / 7781	0592 / 1053
07-	N24	Brembo caliper	1001 / 7781	0592 / 1053
13-	Vantage V8 SP10	Brembo caliper	9196	-
<b>AUDI</b>				
96-99	S3	RS	1001 / 7781	-
96-99	A3	1.8 20v Turbo	0687	0340
95-00	A4	1.8 20v	0687	0340
98-	TT	1.8 Turbo	0687	0340
98-	TT	RS	1001 / 7781	0340
06-08	RS4 (B7)	Brembo Caliper	1266 / 7856	-
02-04	RS6 (C5)	Brembo Caliper	1266 / 7856	-
08-11	RS6 (C6)	Brembo Caliper	9196	-
13-	RS6 (C7)	Brembo Caliper	9196	-
07-	R8	Brembo Caliper	1266 / 7856	7780
94-97	A6	A6, Quattro, Avant	0687	-
02-	S8	Brembo Caliper	0594	7780
<b>BMW</b>				
08-13	135i	E82	1371	1372
10-	1M	E82	0918	0919
85-93	3 Series	E30	0278	0279
86-92	M3	E30	0395	0396
92-99	M3	E36, M3 Evo	0394	0396
01-	M3	E46 (inc CSL)	0394	0548
07-	M3	E92	0918	0919
88-94	M5	E34	0394	0396
08 -	1 Series	E87	0558	-
01-04	3 Series 330i	E46	1061	-
75-82	3 Series	E21	0174	-
90-99	3 Series	E36	0558	0396
98-	3 Series	E46	0558	0396
81-86	5 Series	E28	0395	-
88-95	5 Series	E34	0394	0396
95-	5 Series	E39 not M5	0394	0396
82-89	6 Series	E24	0394	-
2004 -	6 Series	E63, 635 / E64, 630,645,650	0918	0919
86-94	7 Series	E32	0395	0396
94-01	7 Series	E38	0639 / 0960	0548
94-	8 Series	E31	0639 / 0960	0548
97-	Z3	1.8, 2.8	0558	0396
97-	Z3	Coupe, Roadster, 3.2 M	0394	0396
06 -	Z4	Z4 M Coupe	0394	0548
03 -	Z4	E85 / 86	0558	0396
15-	M3	F80	1609	1656
15-	M4	F82/F83	1609	1656
16-	M2	F87	1609	1656
<b>MINI</b>				
02 -	MINI Cooper	Cooper / Cooper S	0939	0940
-08	MINI Cooper JCW	John Cooper Works		1060
<b>CATERHAM</b>				
	Seven Range	STD 2 piston Caliper	0044	0382
	Seven Range	AP7600 Caliper	7834	0382



Make/Year	Model	Application	Front	Rear
<b>CHEVROLET</b>				
66-82	Corvette, Stingray	4 piston caliper	0008	0008
68-69	Camaro	Z28 (4 piston caliper)	0008	0008
05-	Corvette C6	Excluding ZO6	0731	0732
97-05	Corvette C5	Including ZO6	0731	0732
<b>CITROEN</b>				
03-	C2 Sport	Brembo Front Caliper	1001 / 7781	0340
<b>DODGE</b>				
92-02	Viper	Brembo Caliper	0592	0491
03-	Viper SRT-10	Brembo Caliper	7780	7780
<b>FERRARI</b>				
64-66	330 GT	4	0174/7824	-
68-76	365 GTC / GTS	4.4	0174/7824	0252
69-73	246 GT	2.4	0174/7824	0031
73-76	308 GTS / GTB	All	0395	-
73-77	308 GT4 / GTB	2.9	0174/7824	0031
81-89	Mondial	2.9 / 3.2	0395	-
85-89	GTB	2.0	0395	-
85-89	GTS	2.0	0395	-
86-89	328 GTB / GTS	3.2	0395	-
88-92	F40	All	7780	7780
89-93	Mondial	3.4	0345	-
89-95	348 TB / TS	3.4	0345	0345
92-96	512TR (48v)	4.9	0345	0345
92-96	512TR (option)	4.9	7780	0345
93-	355 Sedan / GTS / Spider	3.5	0345	0345
93-	456 GT	All	0639/0960	0345
93-	355 Challenge	Spec	7700 (25mm)	7700 (25mm)
94-95	F512M (48v)	4.9	0345	0345
95-97	F50	All	7780	0592/1053
96-	550 Maranello	All	0639/0960	0345
99-	360 Challenge	Spec	7770 (20mm)	7700 (16mm)
99-	360	All	0592/1053	0592/1053
04	612	5.7	1001/7781	0592/1053
02-	575M	5.7	0639/0960	0345
05-	F430	All	0592/1053	0592/1053
<b>FORD</b>				
91-97	Escort	Cosworth 16v 4x4	7760	0382
02 - 04	Focus Mk1	2.0 RS Brembo Caliper	0592/1053	-
05 -	Focus Mk2	2.5 ST	1305	-
89-93	Sierra	Cosworth 16v 4x4	7760	0382
95-04	Mustang	Cobra	0412	0627
87-93	Mustang	V8	0431	-
07-	Mustang	GT500	7780	1082
<b>HONDA</b>				
93-00	Civic Coupe	Exc. EX & Si models	0273	0503
88-89	Civic CRX	Si	0273	0503
88-91	Civic CRX	DX	0273	0503
91-01	Civic	EG9,EJ1,EJ8,ECT,ESi,VRi	0621	-
93-95	Civic Del Sol	S, Si w/o ABS	0273	-
99-	Civic	Type-R	0829	0537
99-	S2000	2.0 16v	0829	0537
02-	Integra	Type-R DC05	0639/0960	0537
<b>JAGUAR</b>				
98-02	XJ8		0394	-
95-96	XJ12	ATE caliper	0394	0396
95-02	XJR	4.0 Supercharged, Brembo caliper	7780	-
99-	XJR		0394	0396
89-93	XJR-S	6.0	0394	0396
91-94	XJS	4.0, 5.3	0394	0396
97-03	XK8	4.0	0394	0396
98-04	XKR	Brembo caliper	7780	-
<b>LAMBORGHINI</b>				
90-96	Diablo	Brembo caliper	0639 / 0960	0345
97-03	Diablo	Brembo caliper	7780	-

Make/Year	Model	Application	Front	Rear
01-04-	Murciélago Gallardo	Brembo caliper Brembo caliper	7780 7856	7780 7780
<b>LANCIA</b>				
87-89	Delta	Integrale Turbo	0590	-
89-96	Delta	Integrale Turbo	0590	-
91-95	Delta	Integrale Turbo Evo	0592	0340
<b>LEXUS</b>				
00-05	IS300	3.0i V6	0619	0771
93-05	GS300	3.0i V8	0619	0771
98-00	GS400	4.0i V8	0619	0771
01-05	GS430	4.3i V8	0619	0771
96-97	LX450	4.5i V8	0502	-
02-09	SC430	4.3i V8	0619	0771
<b>LOTUS</b>				
96-99-	Elise	1.8	7824	0491
	Elise	1.8 VVC	7824	0491
	Elise (upgrade)	1.8	7745	7824
03-06-	Exige	1.8, 2.2i	7824	0491
06-75-86	Exige	Sport Cup (4 piston)	7834	0491
	Esprit 2.2	S1, S2, S3	7824	-
<b>MARCOS</b>				
97-94-	GTS	2.0	7767	0382
	LM	4.0, 6.0	7767	0382
97-92-	Mantis	4.6	7767	0382
	Mantra	2.0	0345	0382
92-92-	Mantra	2.0 Turbo	7767	0382
	Mantra	4.0, 4.5	7767	0382
99-	Mantaray	4.0, 4.6	7767	0382
<b>MASERATI</b>				
89-93	Ghibli	2.8	0395	0031
93-87-	Ghibli	2.8	0639 / 0960	0031
	430	3.8 Bi Turbo	0395	0031
99-02-	3200GT Spyder	3.2 V8 Bi Turbo V8 4.2	0639 / 0960 0639 / 0960	0345 0345
<b>MAZDA</b>				
85-96	RX-7	Coupe	0463	0482
94-00	MX5	Roadster	0635	0636
06-	MX5	Roadster	1179	1180
<b>McLAREN</b>				
92-98	F1	6.1	7780	7780
<b>MERCEDES</b>				
03-04-	S55	AMG	-	0984
	SLR55	AMG	-	0984
04-06-12	SLR 55 SL 55	AMG AMG	9195 9196	0984 -
<b>MINI (Classic)</b>				
63-71	Cooper, S	2 Piston Caliper 4 Piston Caliper	7720 7765	- -
<b>MITSUBISHI</b>				
94-00	FTO		0530	0532
92-90-	3000GT, GTO Galant	3.0 Twin Turbo VR4	0460 0530	0630 -
92-95	Evo III	AKE caliper	0530	-
96-08	EVO V,VI,VII,VIII,IX	Brembo caliper	1001 / 7781	0109
96-09-	EVO V,VI,VII,VIII,IX EVO X	AKE caliper Brembo caliper	0530 1001 / 7781	0532 1368
92-96	3000 GTO	AKE caliper	0530	-
<b>MORGAN</b>				
66-94	4/4	1.6	0051	-
85-94	Plus 4	2.0	0051	-
83-90	Plus 8	3.5/ 3.5i	7824	-
00-	Aero 8	4.4	7869	7720



Make/Year	Model	Application	Front	Rear
<b>NISSAN</b>				
94-01	200SX	2.0 Turbo	0460	-
90-94	300ZX	3.0 Twin Turbo	0460	-
02-	350Z	Brembo Caliper	0639 / 0960	0109
09-	370Z	Brembo Caliper	1346	1347
93-94	Skyline R32 GT-R	Brembo Caliper	0639 / 0960	0109
95-98	Skyline R33 GT-R	Brembo Caliper	0639 / 0960	0109
99-	Skyline R34 GT-R	Brembo Caliper	0639 / 0960	0109
08-	R35 GT-R	Brembo Caliper	4362	7780
<b>NOBLE</b>				
99-02	M12 GTO	2.6 Twin Turbo	7767	7745
02-	M12 GTO	3.0 Twin Turbo	7869	-
04-	M14	3.0 Twin Turbo	7869	-
2010-	M600	4.4 V8	7672	7671
<b>PORSCHE</b>				
63-65	356	C	0031	-
72-83	911	2.2 / 2.3 / 2.7 / 3.2	0045	0031
77-90	911	3.3 SC Turbo, Turbo Sport	0345	0345
79-87	924	2.0	0252	-
78-85	928	4.5	0252	-
80-85	928	S	0395	-
81-85	928	4.7	0253	-
85-95	928	S & S4 & GT	0447	0345
91-95	928	5.4 GTS 32V	0594	0345
85-87	944	2.5 Turbo	0345	0345
87-91	944	2.5 Turbo	0447	0345
88-91	944	2.7 & 3.0 S2	0345	0345
87-91	959	2.8	0594	0594
88-91	964	C2 3.6	0345	-
91-94	964	C2 3.6	0345	0345
88-94	964	3.6 C4	0345	0345
91-93	964	3.6 Carrera RS	0447	0345
88-91	964	3.3 Turbo & Turbo S	0447	0345
91-93	964	3.3/3.6 Turbo/Turbo S	0594	0345
91-95	968	3.0 Coupe	0345	0345
91-95	968	3.0 Coupe Sport	0447	0345
93-95	968	3.0 Coupe Turbo S	0594	0345
12-	981	Boxster S	1389	0776
13-	981c	Cayman S steel brakes	1389	0738
96-05	986	Boxster	0737	0738
99-05	986	Boxster S	0776	0738
06-09	987c	Cayman S	0737	0738
05-12	987	Boxster	0737	0738
05-12	987	Boxster S	0776	0738
05-12	987	Boxster S ceramic brakes	0991	0776
09-12	987c	Cayman	0776	0738
09-12	987c	Cayman S	0776	0738
11-	991	3.4 C steel brakes	1389	1390
13-	991	GT3 / Turbo / Turbo S steel brakes	7721	7727
13-	991	Cup	7968	7969
93-97	993	3.6 Carrera & C4	0447	0345
95-97	993	3.8 Carrera & C4	0447	0345
95-97	993	3.6 Turbo & Turbo GT2	0594	0447
95-97	993	3.8 Carrera RS & RSR	0594	0447
95-97	993	GT2 & RSR (380 disc)	0594 (25mm)	0447
97-05	996	3.4 C & 3.6	0776	0738
01-	996	C4 S	7818	0776
97-98	996	3.4 C Super-Cup	0594	0776
99-01	996	3.4 C Super-Cup	7818	0776
00-05	996	GT3 R & GT3 RS	0594 (25mm)	7700 (25mm)
99-01	996	GT3 & 996 Turbo	7818	0776
02-	996	Turbo	7818	0776
02-	996	GT3	7819* / 0991	0776
02-	996	GT3 Super-Cup	7819*	0776
02-	996	GT2	7819* / 0991	0776
04-	997	Carrera GT	0991	0776
05-08	997	3.6 C / 3,6 C4	0776	0738
08-	997	3.6 C / 3,6 C4	1389	1299
05-08	997	3.8 C S / 3,8 C4 S	7818	0776



Make/Year	Model	Application	Front	Rear
<b>PORSCHE</b>				
08-	997	3.8 C S/ 3,8 C4 S	7818	1299
09-	997	3.8 GTS	7818	0776
05-	997	all models with PCCB	0991	1299
06-	997	GT3,GT3 RS,Turbo,GT2	0991 / 7819*	1299
05-	997	GT3 Cup	7819*	1299
07-	997	GT3 Cup S / Grand Am	7797 (22mm)	7700 (20mm)
07-	997	GT3R / RSR	7797 (29mm)	7700 (25mm)
* 7819 use on 350mm PFC discs				
<b>RANGE ROVER</b>				
2009-	Sport	5.0 V8	9196	-
<b>RENAULT</b>				
85-90	Alpine	GTA	0292	0516
86-91	R5	GT Turbo	0292	0516
91-98	Clio	1.8 & 2.0 16v Williams	0292	0516
99-	Clio	2.0 16v	0590	0516
00-02	Clio	3.0 V6	0592 / 1053	0592 / 1053
02-04	Clio	3.0 V6 Turbo Sport	7869	0592 / 1053
00 -	Clio	RS (II) 2.0	0590	0516
06-	Clio	RS (III) 2.0 16v	7871	0340
96-99	Megane	2.0 16v Sport	0590	0516
04-	Megane / Clio 197	2 RS	7871	0340
95-97	Sport Spyder		0590	
10-	Megane III RS	Renaultsport 250	1001 / 7781	0340
<b>SEAT</b>				
01-	Ibiza	Turbo R	0592 / 1053	0340
00-	Leon	1.8 20v Turbo Cupra / Sport	0687	0340
02-	Leon	1.8 Cupra R	0592	0340
99-	Toledo	2.3 V5	0687	0340
<b>SKODA</b>				
00-	Fabia	2.0	0687	0340
97-	Octavia	1.8 20v Turbo	0687	0340
01-	Octavia	1.8 Turbo RS	0687	0340
<b>SUBARU</b>				
98-	Impreza	Turbo	0460	0461
01-	Impreza WRX	Sti Brembo Caliper	1001 / 7781	0109
	Impreza	Prodrive P1	0460	0461
	Impreza	Prodrive P1 (upgrade Alcon)	7700	0461
02-	Forester		0929	-
02-	Impreza	Non WRX / Sti	0929	-
02-	Outback		0929	-
12-	BRZ		0929	1124
<b>TOYOTA</b>				
83-87	Corolla	All AKE calipers	0282	-
94-98	Supra	Non Turbo	0619	0630
12-	GT86		0929	1124
<b>TVR</b>				
94-01	Cerbera	4.0, 4.2, 4.5, 5.0	7767	7720
01-	Cerbera	4.0, 4.2, 4.5	7869	0382
93-	Griffith	5.0, AP calipers	7767	0382
04-	Sagaris	4.0	7869	0382
02-	T350	4.0	7869	0382
01-	Tamora	3.6	7869	0382
01-	Tuscan	3.6, 4.0	7869	0382
<b>VAUXHALL</b>				
02-05	Monaro / VXR	5.7	0731	0413
<b>VOLKSWAGEN</b>				
98-	Bora	2.3 & 2.8	0687	0340
99-	Beetle	1.8 Turbo 20v	0687	0340
00-	Beetle	2.3 & 3.2 V6	0687	0340
<b>VOLVO</b>				
03-	S60 / S70 / V70	2.5 Turbo R	1001 / 7781	-

Compound Group

- 13 Compound
- 35 Compound
- 07 Compound
- 05 Compound
- 03 Compound
- 93 Compound
- 83 Compound

13

**13 Compound** is a new generation of ultimate high bite—high friction. 13 compound has been developed with increased bite, modulation, with superior disc conditioning and release characteristics for exceptional control. Ultra smooth and great for tracks with high grip or high downforce cars. It is the ultimate combination of high bite and infinite control.

**Typical Applications;** Ideal use for sprint and severe applications, heavy, high speed applications or high downforce cars where high bite at the first 3rd of the stop is desired. 13's wear is on a par with PFC's legendary 01 compound and will operate at higher temperatures if called to as .13 has a very high threshold for fade resistance. Out of all the high bite, high torque pads in the market 13 has shown to have one of the lowest taper wear in a properly designed race caliper.

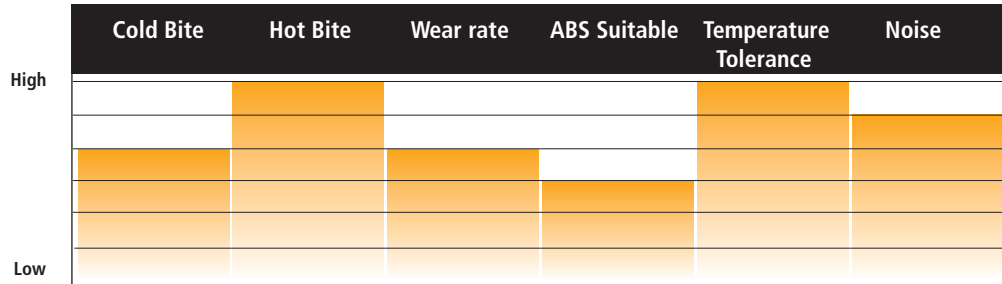

Sprint race, & rally, with competition tyres

Compound Group

- 11 Compound
- 01 Compound
- 99 Compound
- 90 Compound

11

**11 Compound** is a new generation sprint and medium distance friction providing the ultimate in control, with superior disc conditioning. 11 compound was developed from the 01 compound with improved bite, modulation, and release characteristics. It is ultra smooth and developed to reduce wheel locking at the end of a stop. For many applications, 11 will replace the venerable 01 compound.

**Typical Applications;** Ideal for use at medium-low grip venues where control and modulation is a premium. Also in racing applications where ABS systems are used, .11 can be used in a large spectrum of temperature ranges. 11's wear is par with PFC's legendary 01 compound showing virtually zero taper wear when raced in a properly designed race caliper.

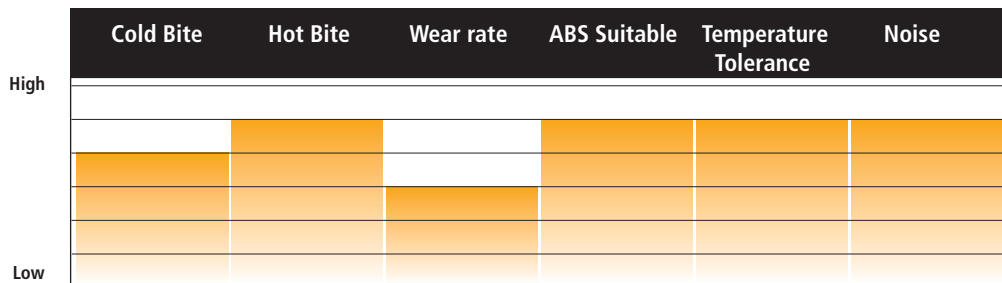

Race & track day with competition / high performance tyres

Compound Group

- 08 Compound
- 06 Compound
- 97 Compound

08

**08 compound** has gained immediate favour in Endurance Sportscar and GT racing and also in endurance production car racing due to its performance in applications where smooth initial bite is a must. 08 has a slight friction rise with temperature with excellent release and modulation characteristics. Very low abraded disc wear with a fine grey slate like disc finish, similar to 01. Despite its considerable performance, 08 wears the longest of all PFC pads and easily matches wear of the other competitors with much higher bite. If temperature isn't an issue, 08 can be replaced with 12 compound. Typical Applications; Endurance, GT and endurance production car racing, trackday



High temp endurance race applications & track day with high performance tyres



### Compound Group

12 Compound  
06 Compound  
97 Compound

# 12

**12 Compound** is a new generation endurance friction—excellent bite with 24 hour durability in its DNA and superior disc conditioning. 12 compound was developed from 08 Compound with improved wear, modulation, and release characteristics. It provides the ultimate in low wear. The PFC .12 Compound won in its debut race the 2013 Daytona 24hr overall winner. 12 compounds wear is lower than 08 when high temperatures is not an issue.

**Typical Applications;** Ideal use for endurance when low wear is at a premium. Also race applications where ABS systems are used. 12's wear is at its optimum when disc temperature paints show 450-500c operating temperatures but will operate at higher temperatures if called to. Virtually zero taper wear when raced in a properly designed race caliper.



Low temp endurance race applications & track day with high performance tyres

### Compound Group

14 Compound  
81 Compound  
80 Compound

# 14

**14 Compound;** Lower friction and slightly less bite than the majority of PFC Race compounds. 14 compound provides high thermal stability and consistency.

**Typical Applications;** Suitable for low grip applications and surfaces with treaded or street tyres.

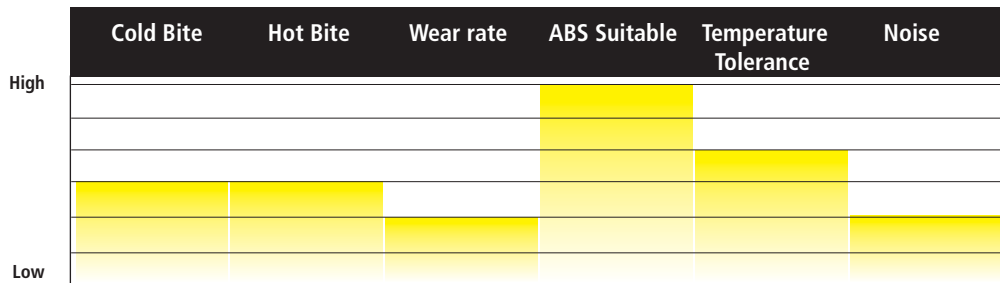

Low grip & Performance road applications

### Compound Group

Z-Rate  
Compound  
.11 Compound  
.10 Compound  
.38 Compound

# Z-Rated

**Z-Rated;** This compound has been developed for fast road / track day applications. It provides more stopping power and increased fade resistance over the std OE materials but retains the good qualities of the road pad i.e., low dusting and noise along with low wear rate.

**Typical Applications;** This compound can be used in OE calipers or aftermarket brake kits in applications where an increase in performance is required over the standard OE friction material.

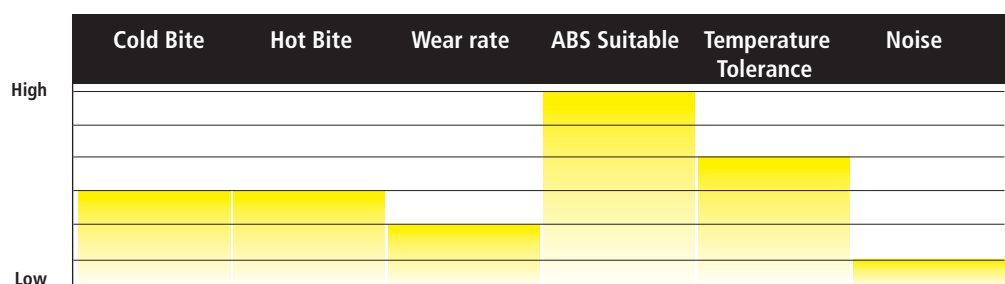

Performance road with noise suppression technologies



## PFC Pads for Competitors Kits

Competitors Pad Part No.	Caliper Pistons	Caliper Type	PFC Part Number
<b>AP Brake kits</b>			
CP3215D50	4 Piston	CP5200	7767
CP3345D44	4 Piston	CP5100	7740 / 7745
CP3894D51	6 Piston	CP5555	7793 / 1247
CP3894D54	6 Piston	CP5555	7790 (17mm)
CP5070D51	6 Piston	CP5570	7793 (17mm)
CP5070D54	6 Piston	CP5555	7790 (17mm)
CP6600D50	4 Piston	CP6600	7870
CP6600D55	4 Piston	CP6600	7869
CP7040D54	6 Piston	CP7040	7877
CP7600D44	4 Piston	CP7600	7834
CP7600D46	4 Piston	CP7600	Call for details
<b>Brembo Brake Kits</b>			
107.5146.31	4 Piston	(A) Family Type	0592
107.4865.80	4 Piston	(B) Family Type	7780
107.5146.13	4 Piston	(C) Family Type	0592
107.5146.13	4 Piston	(F) Family Type	0592
107.9312.44	8 Piston	(G) Family Type	7743
107.4865.80	4 Piston	(H) Family Type	7780
207.9551.13	6 Piston	(J) Family Type	Call for details
XA5.71.M2/XA5.71.M4	6 Piston	(M) Family Type	Call for details
XA5.71.L2/107.9551.13	6 Piston	(N) Family Type	Call for details
107.4865.80	4 Piston	(P) Family Type	7780
<b>Alcon Brake Kits</b>			
PNF4498x821 S / 703.4 / 705.4	4 Piston	Mono Bloc	7631
PNF4497x617.4 / 607.4	6 Piston	Mono Bloc	7876
PNF4497x831 S	6 Piston	Mono Bloc	7672
<b>Stoptech Brake Kits</b>			
	2 Piston	ST22	0109
	4 Piston	ST40	0447
	6 Piston	ST60	7793 / 1247
<b>K-Sport / D2 Brake Kits</b>			
	6 Piston	Front	7767
	8 Piston	Front	7790 (17mm)
	4 Piston	Rear	7745
	6 Piston	Rear	7745
<b>Hi-Spec Brake Kits</b>			
	2 piston	Ultralite	0109 / 7824
	4 Piston	Ultralite	0109 / 7824
	2 piston	Ultralite HB SVA	0051
	4 Piston	Monster	7767
	6 Piston	Monster	7767
	4 Piston	Mega Monster	7793 / 1247
	6 Piston	Mega Monster	7793 / 1247
	4 Piston	R114-4 Narrow Pad	7740
<b>Wilwood</b>			
	4 piston	Dynalite w/ Bridgebolt	0421
	6 piston	GN III Caliper	7753
	4 piston	Billet Narrow Dynalite	7754
	4/6 piston	Superlite	7751



# PAD PROFILES

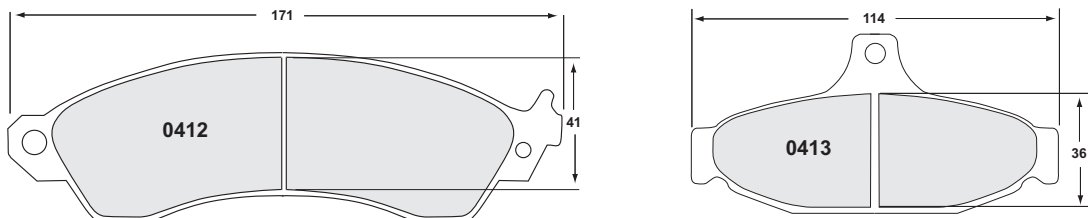
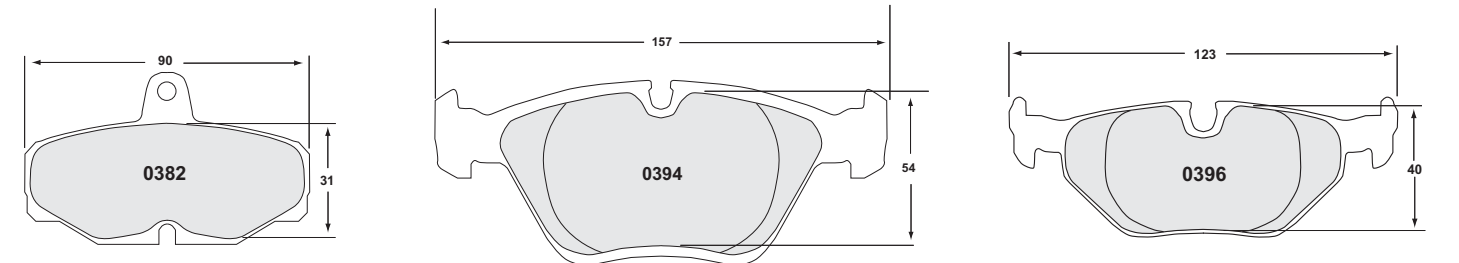
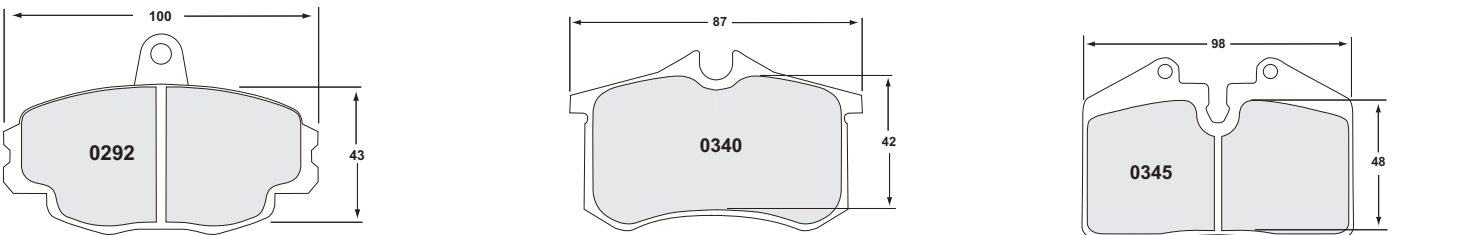
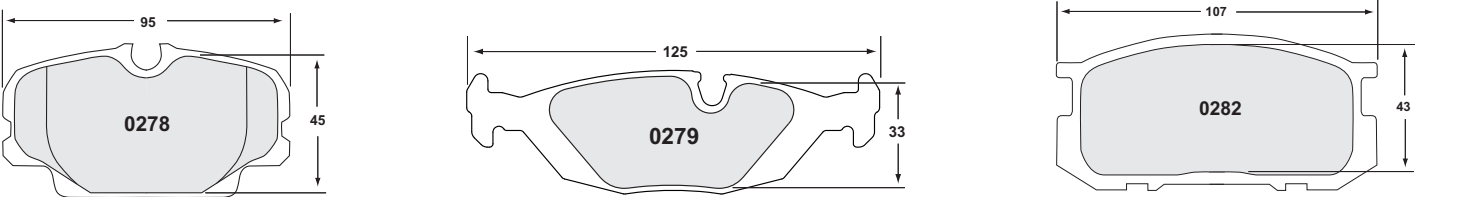
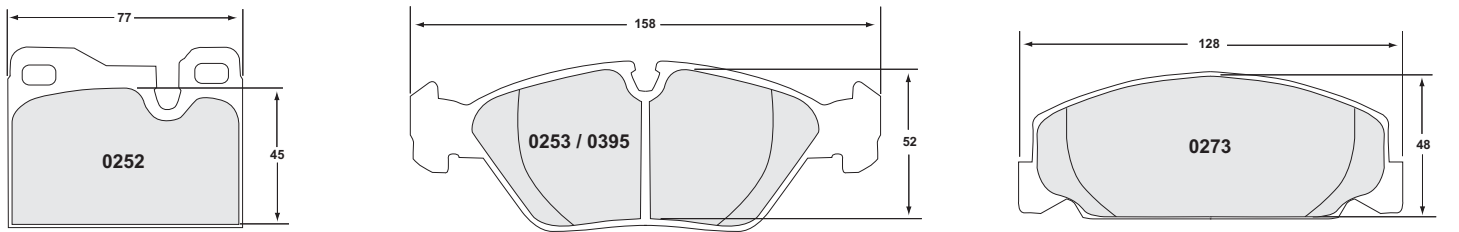
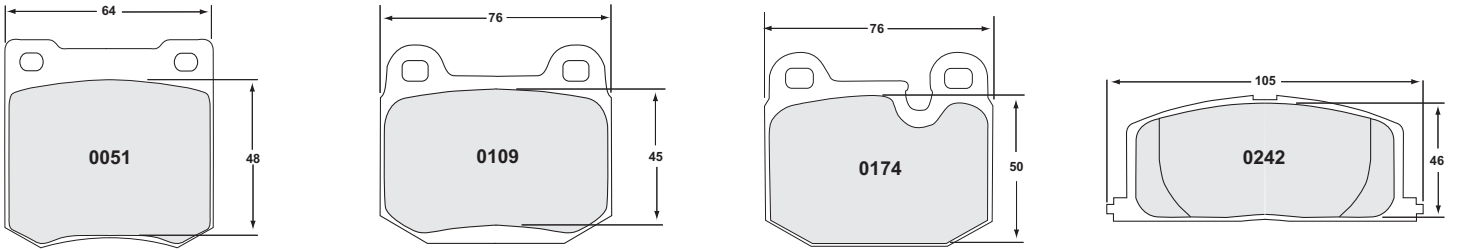
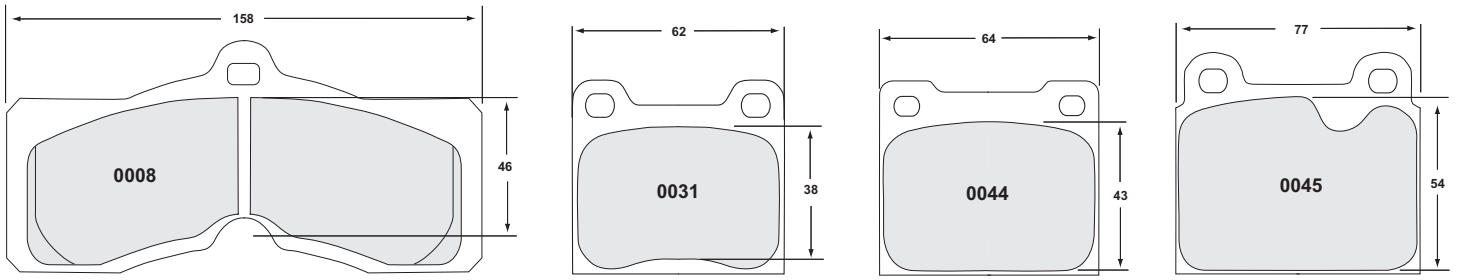

# PAD PROFILES

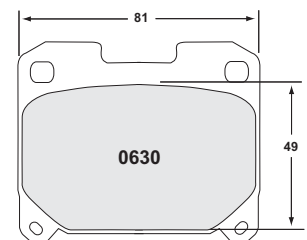
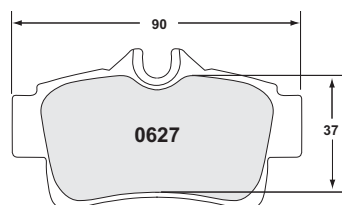
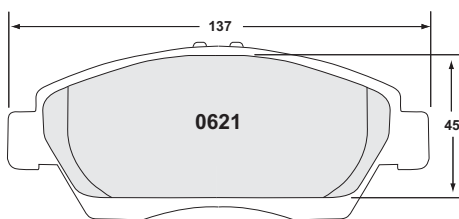
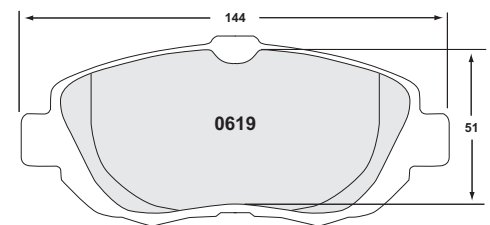
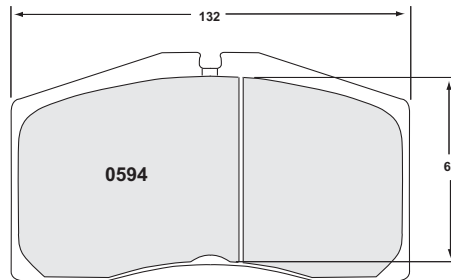
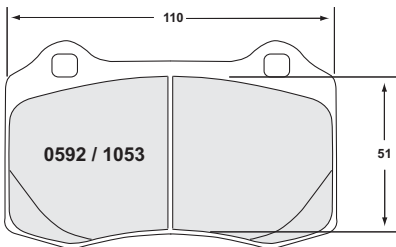
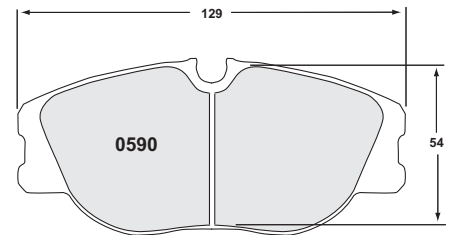
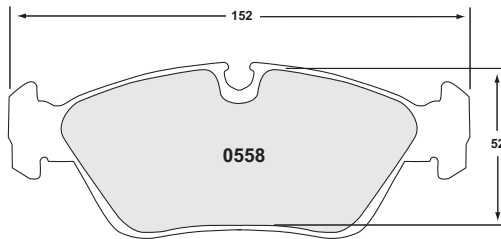
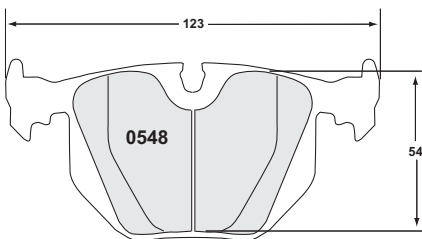
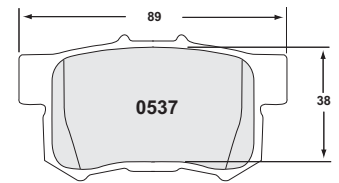
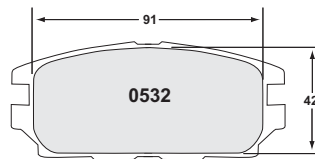
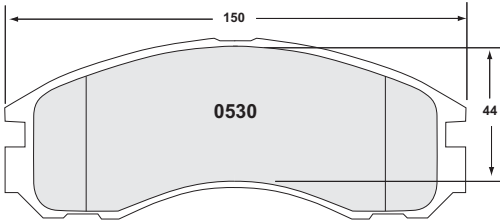
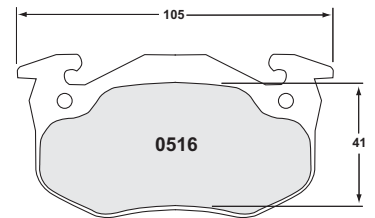
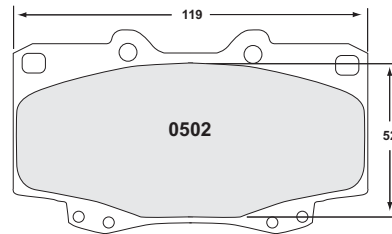
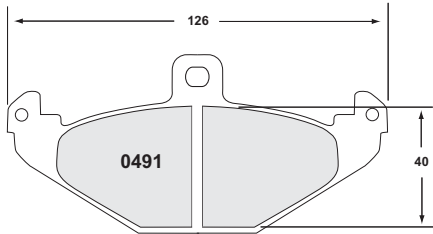
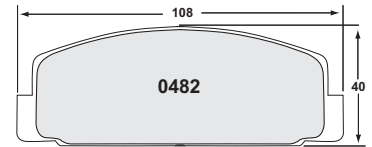
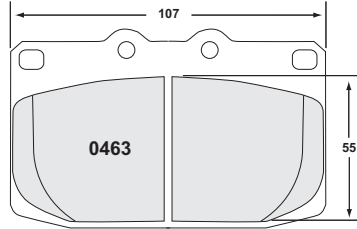
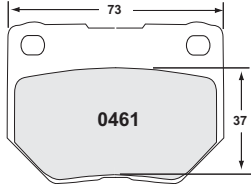
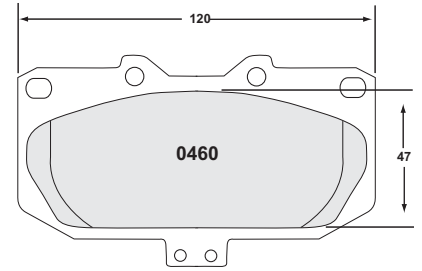
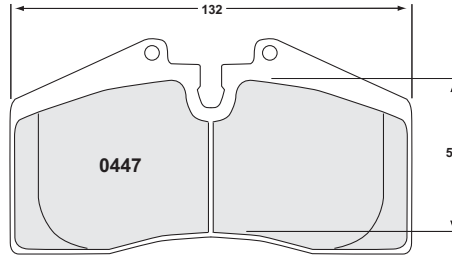
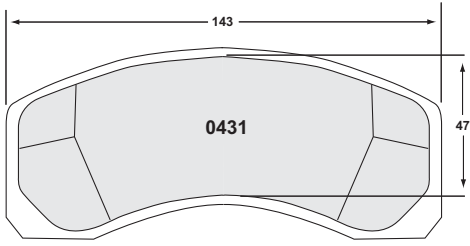

# PAD PROFILES

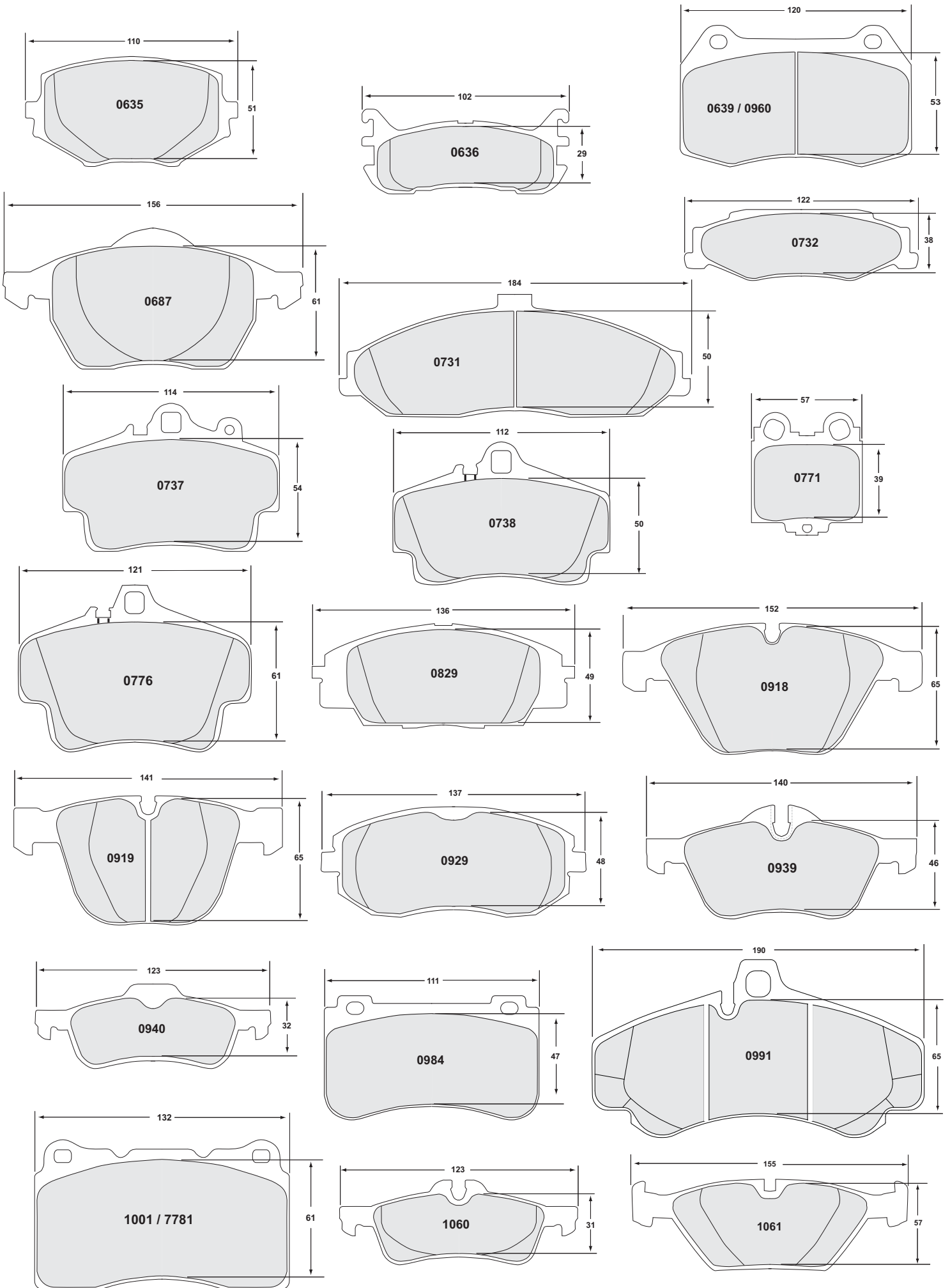

# PAD PROFILES

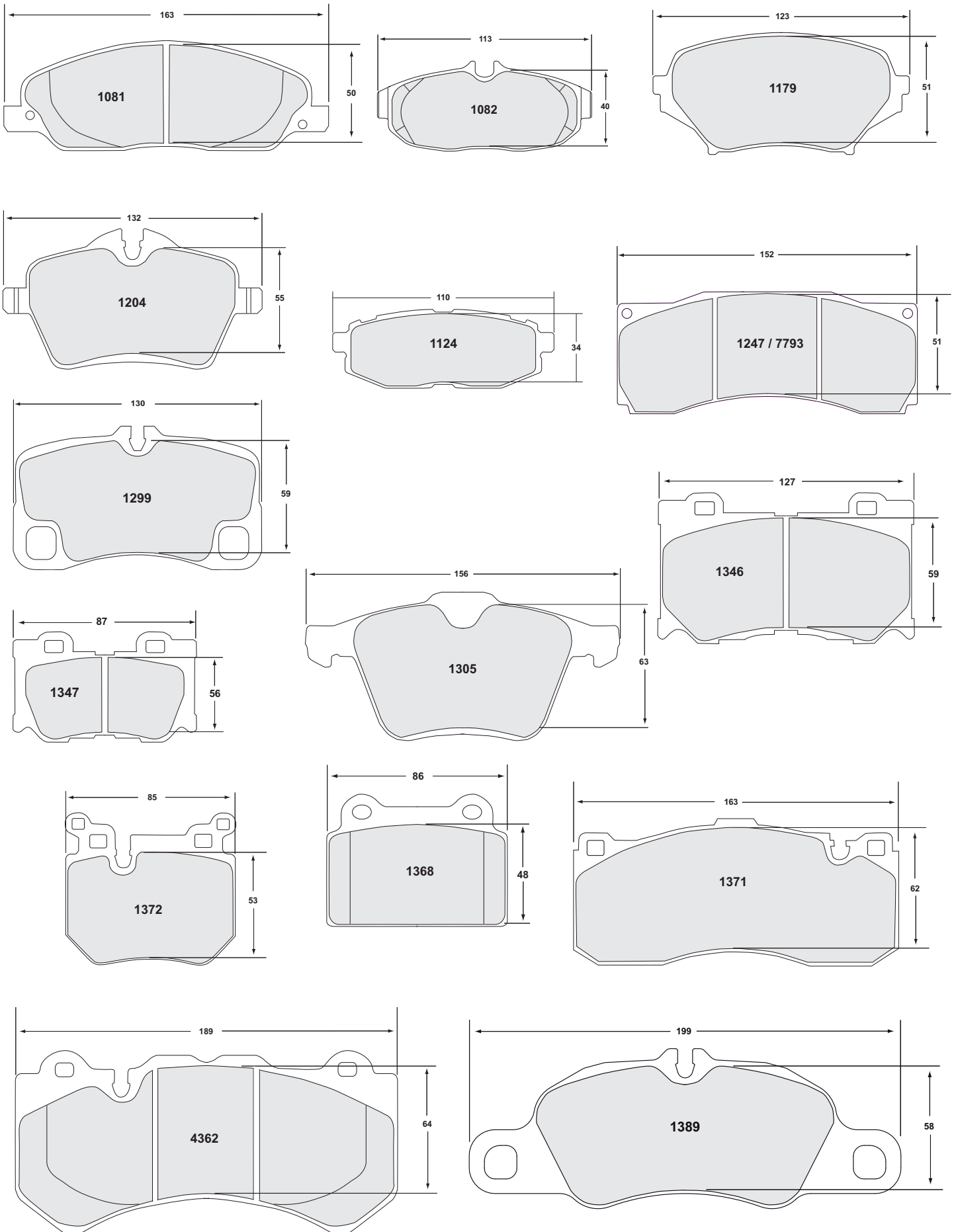

# PAD PROFILES

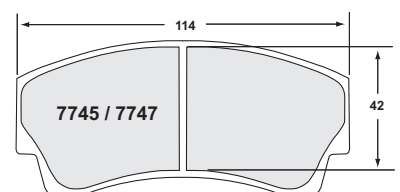
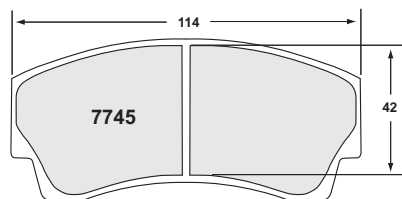
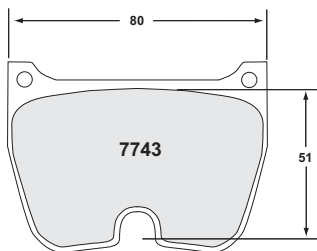
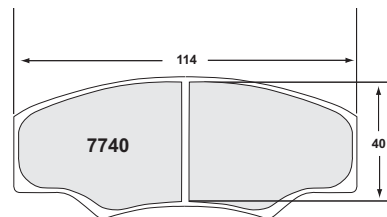
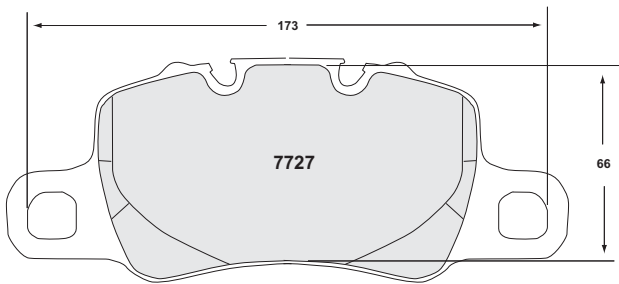
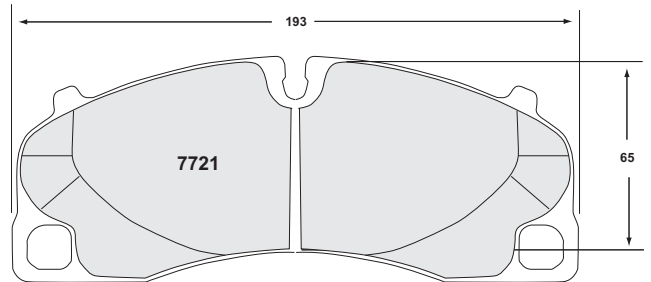
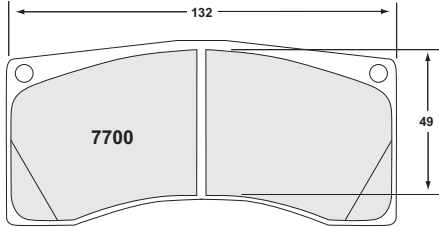
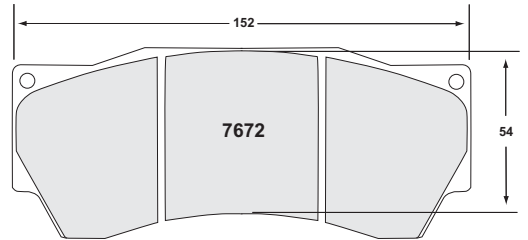
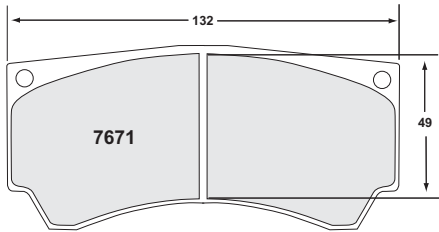
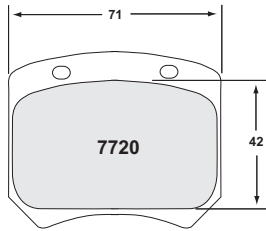
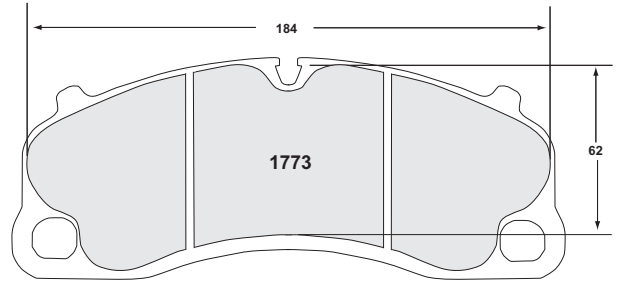
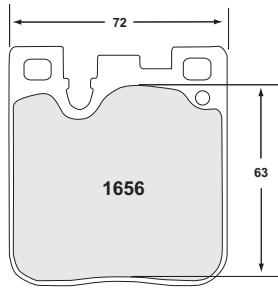
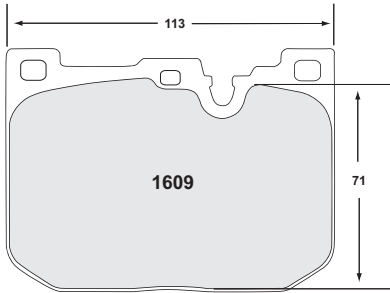

# PAD PROFILES

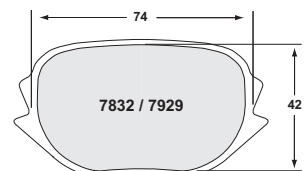
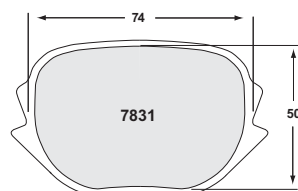
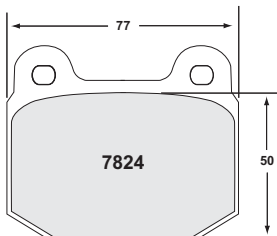
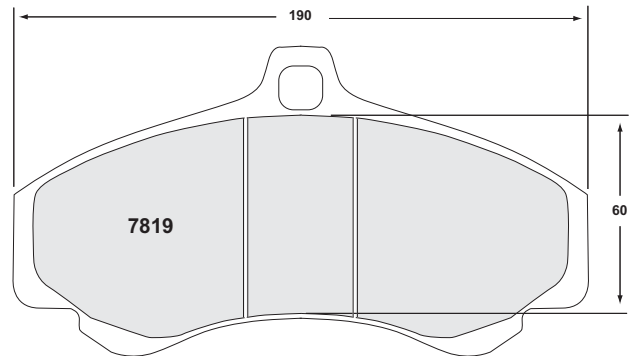
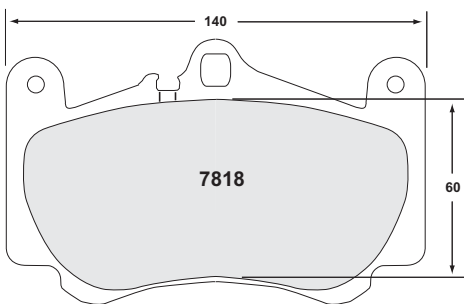
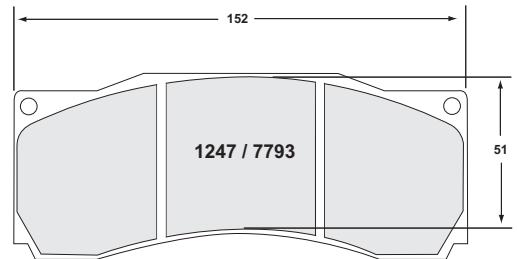
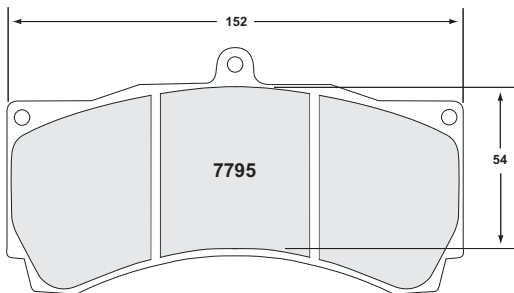
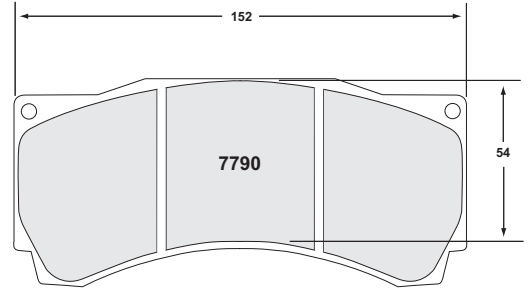
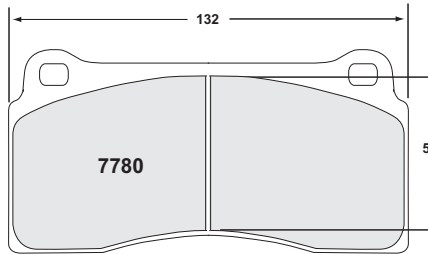
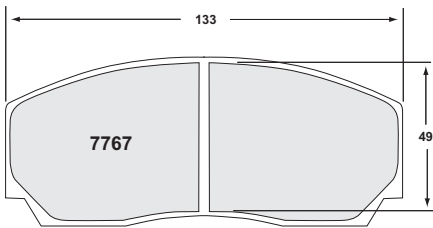
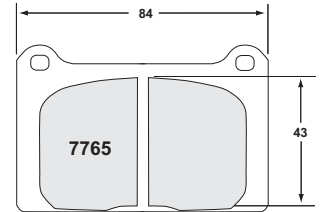
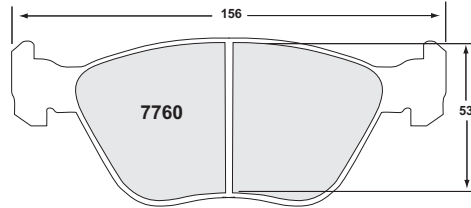
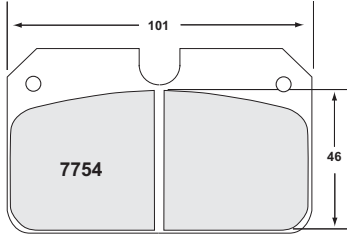
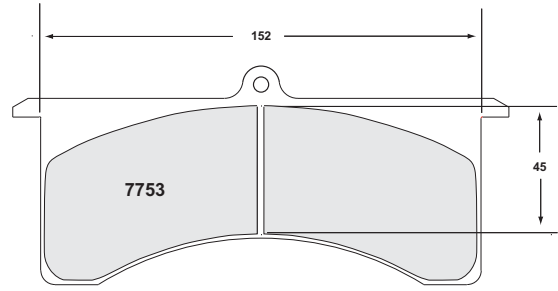
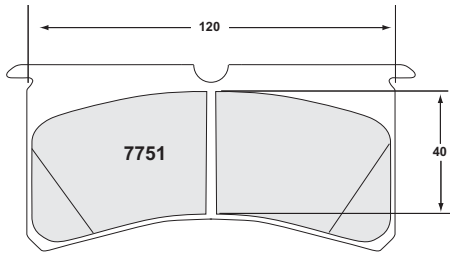



# PAD PROFILES

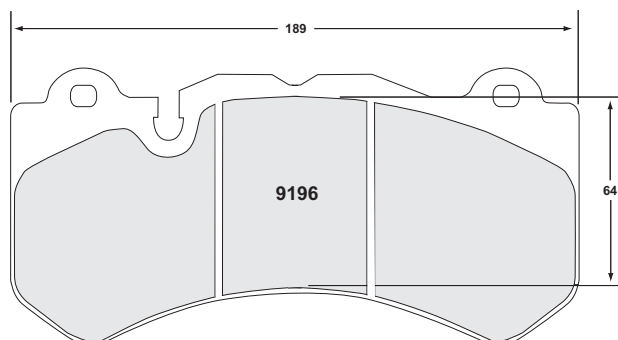
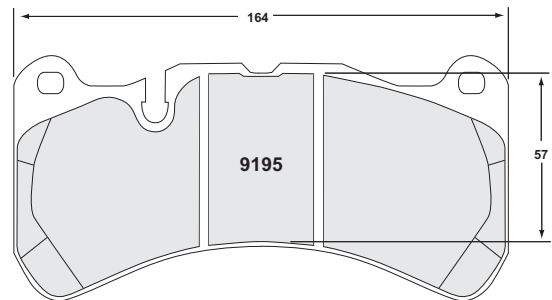
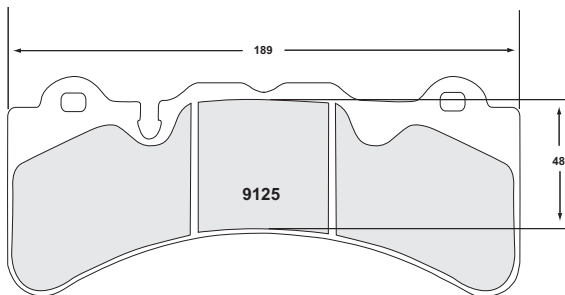
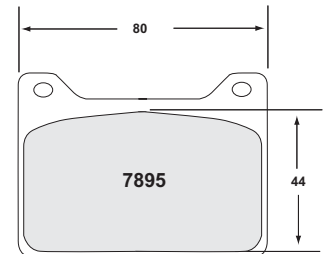
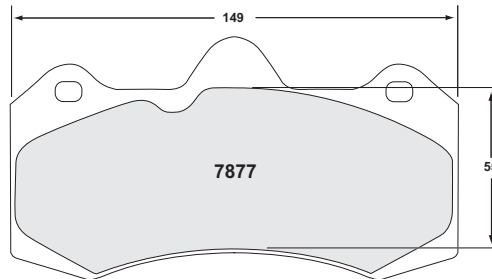
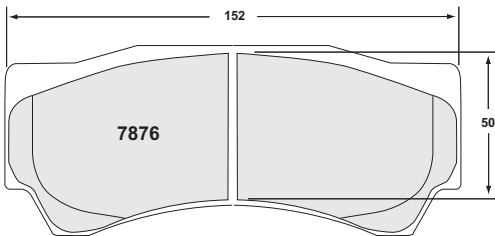
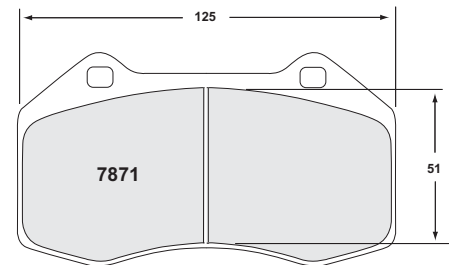
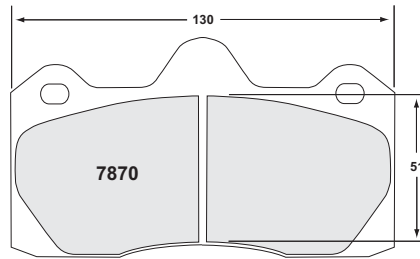
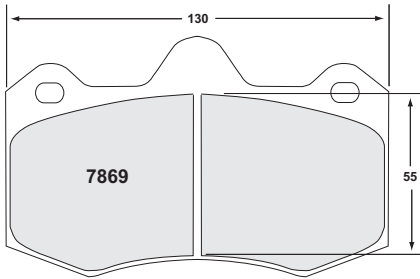
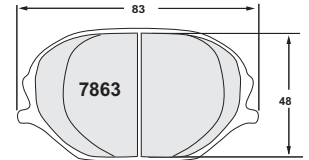
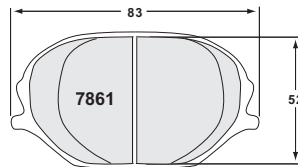
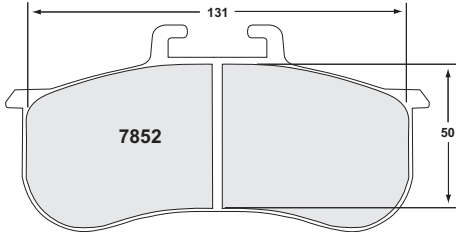
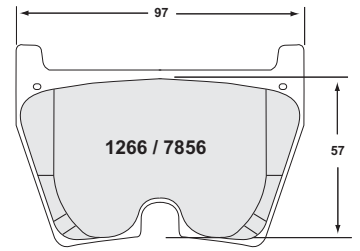
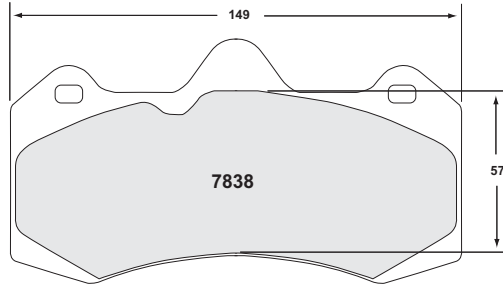
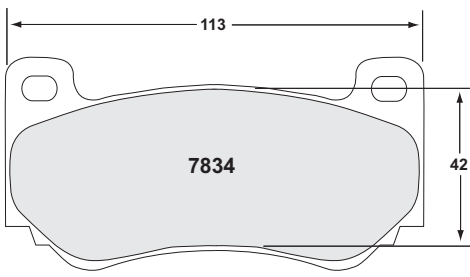

## RH665 DOT 4 RACING BRAKE FLUID

**RH665** is not the same as other Racing Brake Fluids, it has been specially formulated for racing applications, where braking systems operate at very high temperatures.

**RH665** has the highest guaranteed minimum Dry Boiling Point of any DOT 4 Brake Fluid to guard against Vapor Lock and give a rock hard pedal even under extreme racing conditions.

**RH665** also maintains its class leading viscosity, lubricity and compressibility performance at extreme temperatures, to maintain braking system reliability and performance.

For best results bleed the system with fresh fluid before each event, especially if the brakes are excessively hot and/or the conditions are humid.

**RH665** can safely be mixed with other DOT 4 Brake Fluids however this will degrade its properties. **RH665** Racing Brake Fluid conforms to and exceeds the current specification U.S. FMVSS No.116 DOT 4.

Minimum Dry Boiling Point (guaranteed): 325°C (617°F.) Typical Dry BP approaching 330°C.

- Street Legal
- Rock hard pedal



Part No. 025.0037 - 500ml  
Part No. 025.0038 - box of 12

## RH605 HIGH PERFORMANCE DOT 4 BRAKE FLUID

**RH605** High Performance DOT 4 Brake Fluid has been specifically formulated to provide optimum performance in the brake systems of vehicles being used in harsh environments. With excellent high temperature performance to resist brake fade due to vapour lock; Outstanding corrosion resistance and class leading lubricity to prolong system life and enhance ABS operation.

**RH605** High Performance DOT 4 Brake Fluid conforms to and exceeds the current specification U.S. FMVSS No.116 DOT 4 and is completely street legal.

Typical Dry Boiling Point: 300°C (572°F).  
Typical Wet Boiling Point: 196°C (385°F).  
Minimum Dry Boiling Point: 290°C (554°F).  
Minimum Wet Boiling Point: 190°C (374°F).

The result is an exceptional brake fluid with not only a very high boiling point but which also conforms to FMVSS 116 DOT 4 and maintains its class leading viscosity, lubricity and compressibility performance at extreme temperatures to ensure braking system reliability and performance and a extremely firm pedal.

- Street Legal
- Rock hard pedal

**NEW**



Part No. 025.0169 - 500ml  
Part No. 025.0170 - box of 12

**RH605** can safely be mixed with other DOT 4 Brake Fluids however this will degrade its properties.



Part No. 900.900.001.26

## PRESSURE BLEEDER KIT

This makes refilling / flushing and bleeding the entire brake or clutch system a one man operation - completely removing the need for pumping the brake pedal, taking its power from a 12 volt battery.

- Consistant pressure bleeding
- Built in reservoir and low level cut out
- Supplied with universal vehicle reservoir cap
- 12 volt supply clamps

## BRAKE BLEEDER BOTTLE - TWIN APPLICATION



Part No. 026.0001

The PFC Brake bleed bottle makes bleeding your brakes easy, clean and quick, even when dealing with hot fluid.

- Developed for competition use and can be operated by one person
- Temperature resistant, suitable for bleeding hot or cold fluids
- Twin bleed enables both sides of the caliper to be bled at the same time
- Clear hoses gives visual inspection for air bubbles in the system
- High quality valves ensure no air enters the system

## MECHANICS GLOVES

- Part No. 041.0001 S  
041.0002 M  
041.0003 L  
041.0004 XL  
041.0005 XXL



## TEMPERATURE TABS



Part No. 032.0007

## BRAKE DISC TEMPERATURE KIT

Kit comprises of three paints for monitoring peak brake disc temperatures.

- Green changes to White at 430°
- Orange changes to Yellow at 560°
- Red changes to White at 610°

Kit also contains thinners and three brushes.



Part No. 032.0003

**PFC**  
**BRAKES**



**PFC V3**

**Performance Friction Europe**

Tel: +44(0)1295 221020  
uksales@pfcbrakes.com

[www.pfcbrakes.eu](http://www.pfcbrakes.eu)



@pfcbrakeseurope